

# Maintenance Manual DG-500

## 0 General

### 0.1 Manual amendments

No.	Page	Description	Date
0.1	all	Combination of the initial Maintenance Manuals of the Variants DG-500/22 ELAN, DG-500 ELAN Trainer, DG-500/20 ELAN and DG-500 ELAN Orion, new standardized format	December 2009
0.2	0.8, 1.9, 1.14, 4.2, 5.1, 6.1, 6.2	Miscellaneous changes to the contents of the latest amendments of the initial maintenance manuals	December 2009
1	0.3, 0.4, 0.7, add diagram 7a	Wheel brake TN500/03	July 2011
2	0.3, 0.4, 0.7, 1.11, 2.1, 2.3, 2.4, 4.5, 4.6, file working instruction No. 1 for TN348/20 issue 3 at the end of the MM	Headrest securing ropes in the rear cockpit, manual amendments TN500/05	September 2011
3	0.1, 0.3, 0.4, 1.4, 1.12, 1.16, 2.1 – 2.4, 6.3, diagrams 9 and 9b	TN500/13 Canopy lock, rear locking rods, manual revision	July 2019
4	0.1, 0.3, 1.2, 1.3	TN500/17 adjustment of elevator free play	December 2023

## Maintenance Manual DG-500

### 0.2 List of effective pages

Section	page	issued	replaced /	replaced /	replaced /
0	0.0	December 09			
	0.1	See manual amendments			
	0.2	See manual amendments			
	0.3	See manual amendments			
	0.4	See manual amendments			
	0.5	December 09			
	0.6	"			
	0.7	"	July 11	September 11	
	0.8	"			
1	1.1	December 09			
	1.2	"	December 23		
	1.3	"	December 23		
	1.4	"	July 19		
	1.5	"			
	1.6	"			
	1.7	"			
	1.8	"			
	1.9	"			
	1.10.	"			
	1.11.	"	September 11		
	1.12.	"	July 19		
	1.13.	"			
	1.14.	"			
	1.15.	"			
	1.16.	"	July 19		
	1.17.	"			
2	2.1	December 09	September 11	July 19	
	2.2	"	July 19		
	2.3	"	September 11	July 19	
	2.4	"	September 11	July 19	
	2.5	"			
3	3.1	December 09			
	3.2	"			
	3.3	"			
	3.4	"			
4	4.1	December 09			
	4.2	"			
	4.3	"			
	4.4	"			
	4.5	"	September 11		
	4.6	"	September 11		
	4.7	"			

## 1.2 Elevator control and trim system

### 1.2.1 Control system see diagram 1

### 1.2.2 Elevator deflections and tolerances

Up 25.5° - 26°

Down 23.5° - 24°

measured at 227 mm (8.94 in.) from hinge axis.

Measurement:

Hold a measuring stick with one end on the floor.

Set the elevator to zero by using a pattern. A drawing for the zero-pattern is available from DG Flugzeugbau.

Mark the 0-point on the stick.

Then measure the up and down deflections.

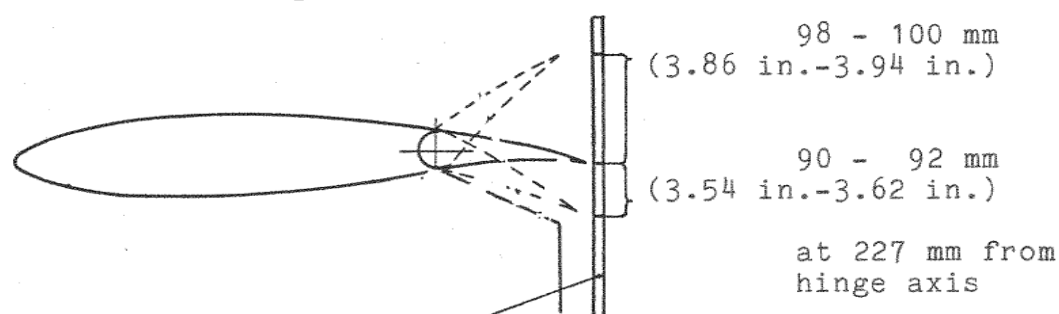

measuring stick one end on the floor

### 1.2.3 Elevator stops

The elevator stops are located at the rear control column and can be adjusted with a 10 mm open end wrench.

### 1.2.4 Elevator control circuit free play

With the elevator held fixed in the zero position, the free play at the top of the control column can be  $\pm 2$  mm ( $\pm 0.08$  in.).

#### Free play within the automatic elevator connection

Within the automatic elevator connection there should be no free play noticeable in the zero position when the elevator is moved at its trailing edge.

Any free play can be reduced by screwing in the adjustment screw on the automatic connector funnel.

**Warning:** In case the adjustment screw was turned in too far, the roller will jam inside the funnel and can't be moved or only with larger force to the front of the funnel. Moving the horizontal tailplane backwards for rigging might not be possible or only with large effort. Each time a bending force will act on the rod end which might lead to failure of the rod end with time.

For this reason after adjusting the free play it is necessary to check if the roller can be moved without force in the funnel.

## Maintenance Manual DG-500

To accomplish this, remove the complete rod end with the roller or remove the roller from the rod end and stick it on an 8 mm f7 pin and move the roller in the funnel. Prior to removal of the rod end mark its position.

If the roller can't be moved without force completely to the front you must turn back the adjustment screw and bend back the sheet metal which was bent by the adjustment screw. Then adjust the free play again.

In case the roller has too much free play on the rod end or if the roller is no more round you must replace the roller by a new one 5St95/3.

In case the glider was operated for a longer time with the adjustment screw turned in too far the rod end must be replaced by a new one 5St94.

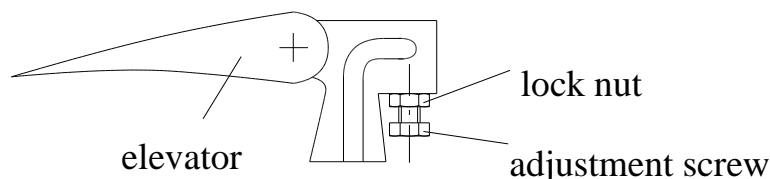

After completion of this work check the elevator displacements and adjust if necessary.

### 1.2.5 Trim

The trim mechanism should be adjusted so that with full forward (nose down) trim the control column is in the maximum forward position.

The tensioning of the trim mechanism springs is adjusted as shown in the sketch.  $x = 340$  mm (13.4 in.)

The springs are located in the rear cockpit on the left hand side.

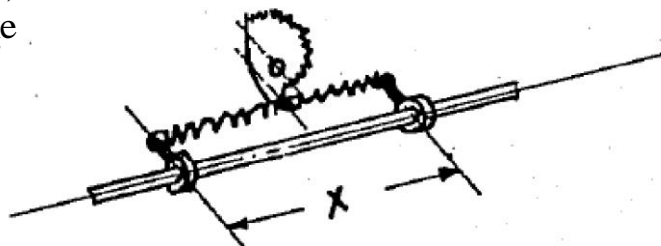

### 1.2.6 Pilot force reducing rubbercord

The rubber cord produces an elevator stick force in push direction. If the trim efficiency of your DG-500 in push direction is reduced, you have to inspect the rubber cord.

The rubber cord is located on the left hand side behind the main bulkhead below the baggage compartment floor.

The rubber cord runs from bellcrank 5St19 to a fork at the main bulkhead. The length of the rubber cord when loose should be 500 mm (19.7 in.).

If the cord is longer or worn it must be replaced.

The cord must be replaced at least every 6 years.