

Maintenance Manual DG-600

0 General

0.1 Amendments

No.	Page	Description	Date
0.1	all	Combination of the initial Maintenance Manuals of the Variants DG-600 and DG-600/18, new standardized format	December 2009
0.2	0.7, 1.2, 1.4, 1.10-1.12, 2.1, 2.3, 2.5, 3.1 - 3.3, 4.2, 4.7, 5.1, 6.1 - 6.4, diagram 1a	Miscellaneous changes to the contents of the latest amendments of the initial maintenance manuals	December 2009
1	0.1, 0.3, 0.4, 0.6, 1.1, 1.3 - 1.6, 4.6, 8.1 diagrams 3a, 7c, 6F39	Manual revision TN DG-SS-07	August 2021
2	0.1, 0.3, 1.2 - 1.4	TN DG-SS-09 adjustment of elevator free play	December 2023

Maintenance Manual DG-600

0.2 List of effective pages

Section	page	issued	replaced	replaced	replaced
0	0.0	December 09	See manual amendments		
	0.1	"	"		
	0.2	"	"		
	0.3	"	"		
	0.4	"	"		
	0.5	"			
	0.6	"	August 2021		
	0.7	"			
	0.8	"			
1	1.1	December 09	August 2021		
	1.2	"	December 23		
	1.3	"	August 2021	December 23	
	1.4	"	August 2021	December 23	
	1.5	"	August 2021		
	1.6	"	August 2021		
	1.7	"			
	1.8	"			
	1.9	"			
	1.10	"			
	1.11	"			
	1.12	"			
	1.13	"			
	2	2.1	December 09		
2.2		"			
2.3		"			
2.4		"			
2.5		"			
2.6		"			
3		3.1	December 09		
	3.2	"			
	3.3	"			

1.2 Elevator control and trim system

1.2.1 Control system

see diagram 1a

1.2.2 Elevator deflections and tolerances

ser. no.'s	all except for 6-24		6-24 (with HT DG-800)	
	mm	in	mm	in
Up	61.5 \pm 1	2.42 \pm 0.04	46 \pm 2	1.81 \pm 0.08
Down	55 \pm 1	2.17 \pm 0.04	46 \pm 2	1.81 \pm 0.08
measured behind hinge axis at	160	6.3	134	5.3

Measurement:

Hold a measuring stick with one end on the floor. Deflect the elevator to neutral position by bringing the mark at the sealing in line with the upper end of the fin. Mark the 0-point on the stick. Then mark the up and down displacement.

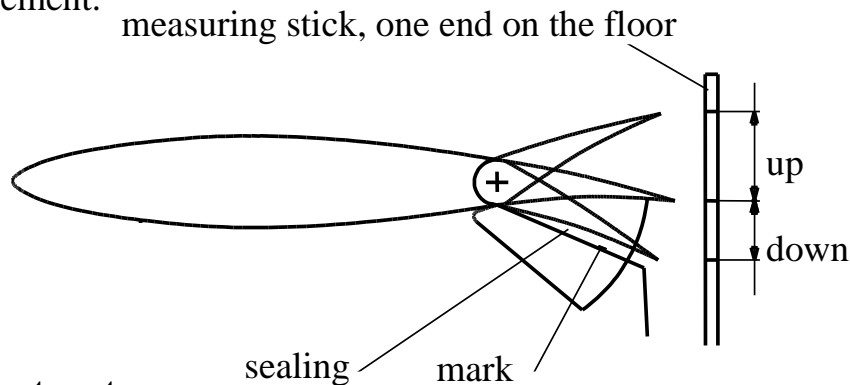

1.2.3 Elevator stops

The elevator stops are located at the base of the control column and can be adjusted with a 10 mm open ended spanner.

1.2.4 Elevator control circuit free play

With the elevator held fixed in the zero position, the free play at the top of the control column can be \pm 1.5 mm (\pm 0.06 in.).

Free play within the automatic elevator connection

Within the automatic elevator connection there should be no free play noticeable in the zero position when the elevator is moved at its trailing edge.

Any free play can be reduced by screwing in the adjustment screw on the automatic connector funnel.

Warning: In case the adjustment screw was turned in too far, the roller will jam inside the funnel and can't be moved or only with larger force to the front of the funnel. Moving the horizontal tailplane backwards for rigging might not be possible or only with large effort. Each time a bending force will act on the rod end which might lead to failure of the rod end with time.

For this reason after adjusting the free play it is necessary to check if the roller can be moved without force in the funnel.

Maintenance Manual DG-600

To accomplish this, remove the complete rod end with the roller or remove the roller from the rod end and stick it on an 8 mm f7 pin and move the roller in the funnel. Prior to removal of the rod end mark its position.

If the roller can't be moved without force completely to the front you must turn back the adjustment screw and bend back the sheet metal which was bent by the adjustment screw. Then adjust the free play again.

In case the roller has too much free play on the rod or if the roller is no more round you must replace the roller by a new one 6St50/2.

In case the glider was operated for a longer time with the adjustment screw turned in too far the rod end must be replaced by a new one 6St50/1.

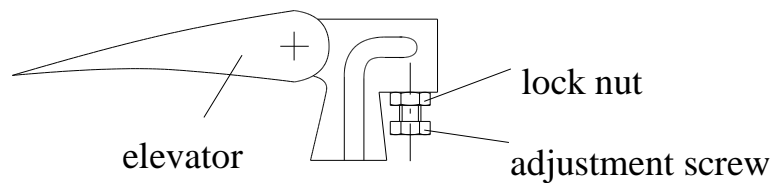

After completion of this work check the elevator displacements and adjust if necessary.

1.2.5 Trim

The automatic trim mechanism should be adjusted so that with full forward (nose down) trim the control column is in the maximum forward position. The tensioning of the trim mechanism springs is adjusted as shown on the sketch.

$x = 360 \text{ mm (14.2 in.)}$

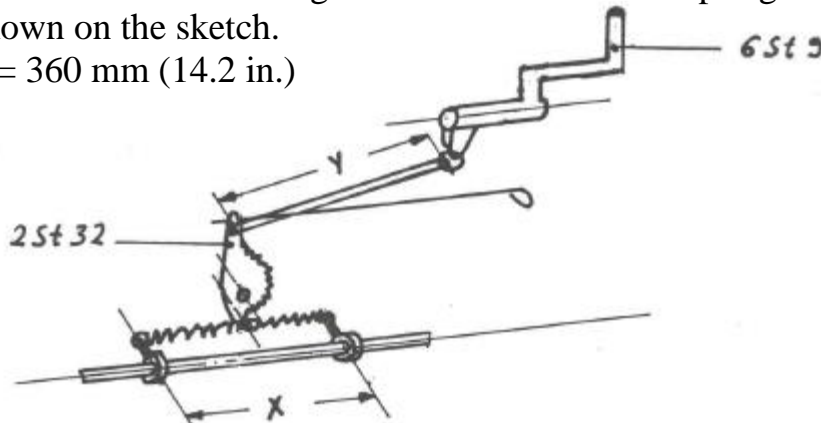

The bungee interconnection between wing flap lever 6 St 9 and trim lever 2 St 32 is to be replaced, when worn or when elongated.

The length in unstretched condition y must be 110 mm (4.3 in.). The interconnection consists of 2 mm diam. bungee layer around 3 times.

1.2.6 Repair of the automatic trim mechanism bowden cable

In the event of a replacement bowden cable being installed, it should be cautioned that the cable must pass between the two parallel arms of the control column mechanism as shown in the sketch.

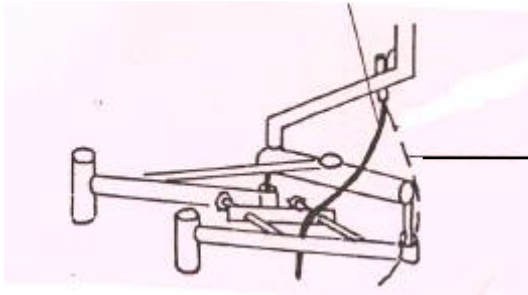

Warning: If the cable passes outside the mechanism column movement can be blocked.

1.2.7 Sealing the elevator

The elevator is sealed with a Teflon coated glass fibre fabric loop, see section 4.6a. Partlist see section 8.

1.3 Rudder control

1.3.1 Rudder control circuit

see diagram 2a

1.3.2 Rudder deflections and tolerances

165-5 mm ($\pm 30^\circ$) (6.5 - .2 inch)
measured at 318 mm (12.52 inch) from the hinge axis.

1.3.3 Rudder stops

The rudder stops are located at the lower hinge pedestal and can be adjusted with an allen key wrench.

1.3.4 Axial free Play

The maximum allowable free play at the upper hinge point is 0.5 mm (0.02 inch)

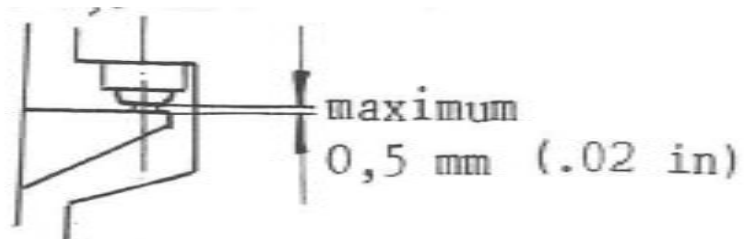

1.3.5 Sealing the rudder

The rudder is sealed on both sides with a V sealing tape (3 M Scotch Flexodicht Band 2743 white) which is attached at the fin trailing edge. This seal is not to be removed. If damaged it should be replaced and sprayed with Teflon spray.
Partlist see section 8.