

Maintenance Manual DG-300

0 General

0.1 Amendments

No.	Page	Description	Date
0.1	all	Combination of the initial Maintenance Manuals of the Variants DG-300, DG-300 ELAN, DG-300 ELAN ACRO, DG-300 Club ELAN and DG-300 Club ELAN ACRO, new standardized format	December 2009
0.2	0.7, 1.10, 1.12, 2.1, 2.4, 3.2, 4.1, 4.2, 5.1, 5.2, 6.1, 6.2	Miscellaneous changes to the contents of the latest amendments of the initial maintenance manuals	December 2009
1	0.1, 0.3 – 0.8, 1.4, 2.1, 6.3, 8.8 – 8.12, 9.9 – 9.12	TN DG-SS-05 Manual revision Inclusion of TN359/4 and TN359/24	August 2020
2	0.1, 0.3, 1.2, 1.3	TN DG-SS-09 adjustment of elevator free play	December 2023

Maintenance Manual DG-300

0.2 List of effective pages

Section	page	issued	replaced	replaced	replaced
0	0.0	December 09			
	0.1	see manual amendments			
	0.2		"		
	0.3		"		
	0.4		"		
	0.5	December 09	August 20		
	0.6	"	August 20		
	0.7	"	August 20		
	0.8	August 20			
1	1.1	December 09			
	1.2	"	December 23		
	1.3	"	December 23		
	1.4	"	August 20		
	1.5	"			
	1.6	"			
	1.7	"			
	1.8	"			
	1.9	"			
	1.10.	"			
	1.11	"			
	1.12	"			
2	2.1	December 09	August 20		
	2.2	"			
	2.3	"			
	2.4	"			
	2.5	"			
	2.6	"			
3	3.1	December 09			
	3.2	"			
	3.3	"			

1.2 Elevator deflections and adjustment

1.2.1 Control circuit

see diagram 1

1.2.2 Elevator deflections and tolerance:

Up 63 ± 1 mm $2,48 \pm 0,04$ inch

Down 36 ± 1 mm $1,42 \pm 0,04$ inch

measured 150 mm (5,9 inch) from hinge axis.

The adjustment is made at the base of the control column. To measure the displacement lay a straight edge over the elevator and trailing surface of the stabilizer (which is flat in this area). The straight edge must lie parallel to the stabilizer surface. Holding a measuring stick with one end on the floor mark the 0 point on the stick. Then measure the up and down displacements from this zero point.

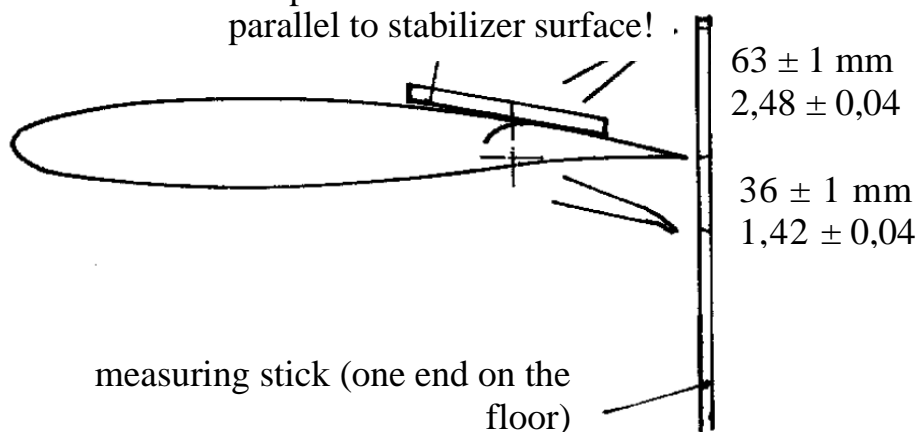

1.2.3 Elevator stops:

The elevator stops are located at the base of the control column and can be adjusted with a 10 mm open ended spanner.

1.2.4 Elevator control circuit free play:

The play at the top of the control stick must not exceed ± 1.5 mm (± 0.06 in.) when the elevator is firmly held in neutral position.

Within the automatic elevator connection there should be no free play noticeable in the zero position when the elevator is moved at its trailing edge.

Any free play can be reduced by screwing in the adjustment screw on the automatic connector funnel.

Warning: In case the adjustment screw was turned in too far, the roller will jam inside the funnel and can't be moved or only with larger force to the front of the funnel. Moving the horizontal tailplane backwards for rigging might not be possible or only with large effort. Each time a bending force will act on the rod end which might lead to failure of the rod end with time.

For this reason after adjusting the free play it is necessary to check if the roller can be moved without force in the funnel.

Maintenance Manual DG-300

To accomplish this, remove the complete rod end with the roller or remove the roller from the rod end and stick it on an 8 mm f7 pin and move the roller in the funnel. Prior to removal of the rod end mark its position.

If the roller can't be moved without force completely to the front you must turn back the adjustment screw and bend back the sheet metal which was bent by the adjustment screw. Then adjust the free play again.

In case the roller has too much free play on the rod end or if the roller is no more round you must replace the roller by a new one 2L24.

In case the glider was operated for a longer time with the adjustment screw turned in too far the rod end must be replaced by a new one 2L19/1.

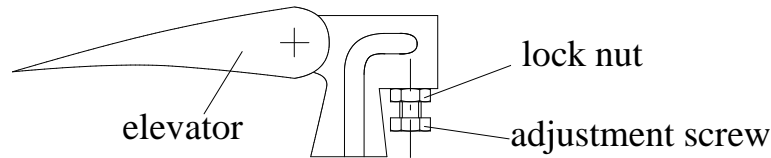

After completion of this work check the elevator displacements and adjust if necessary.

1.2.5 Trim:

The automatic trim mechanism should be adjusted so that with full forward (nose down) trim, the control column is from 1 to 1,5 cm (0,4 – 0,6 inch) away from its maximum forward position. The tensioning of the trim mechanism springs is to adjust as shown on the sketch. (360 mm; 14,2 inch)

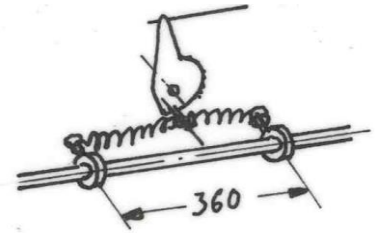

1.2.6 Repair of the automatic trim mechanism bowden cable:

In the event of a replacement bowden cable being installed, it should be ensured that the cable passes between the two parallel arms of the control column mechanism as shown in the sketch.

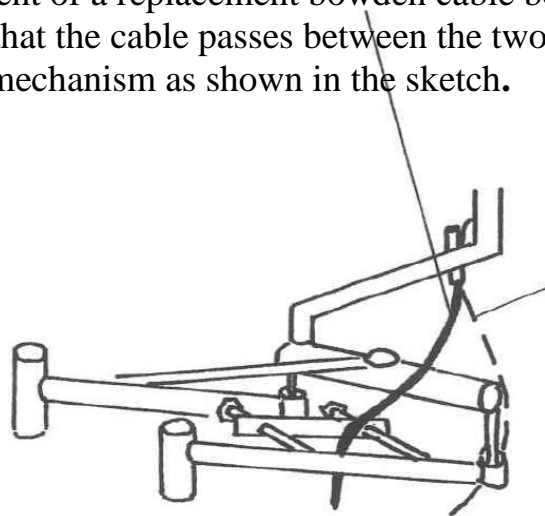

Note: if the cable passes outside the mechanism control column movement could be blocked