

**0.1 Log of Revisions**

Any revision of the present manual, except actual weighing data, must be recorded in the following table and in case of approved Sections endorsed by the responsible airworthiness authority.

The new or amended text in the revised page will be indicated by a black vertical line in the right hand margin, and the revision No. and the date will be shown on the bottom left hand of the page.

Rev. No.	Pages affected	Description	Date	EASA Approval
1	0-2, 0-3, 4-7, 4-13, 4-14, 7-2	TN8019 wheel brake actuated by airbrake handle	February 2011	13.10.11

0.2 List of Effective Pages

Chapter	Page	Date	Chapter	Page	Date
0	Title page	February 2002	4	4-14	February 2011
	0-1	February 2002		4-15	February 2002
	0-2	February 2011		4-16	February 2002
	0-3	February 2011		4-17	February 2002
	0-4	February 2002			
1	1-1	February 2002	5	5-1	February 2002
	1-2	February 2002		5-2	February 2002
				5-3	February 2002
2	2-1	February 2002	6	6-1	February 2002
	2-2	February 2002		6-2	February 2002
	2-3	February 2002	7	7-1	February 2002
	2-4	February 2002		7-2	February 2011
	2-5	February 2002		7-3	February 2002
	2-6	February 2002		7-4	February 2002
	2-7	February 2002		7-5	February 2002
	2-8	February 2002		7-6	February 2002
3	3-1	February 2002	8	8-1	February 2002
	3-2	February 2002		8-2	February 2002
	3-3	February 2002		8-3	February 2002
	3-4	February 2002		8-4	February 2002
	3-5	February 2002		8-5	February 2002
	3-6	February 2002		8-6	February 2002
4	4-1	February 2002	9	9-1	February 2002
	4-2	February 2002			
	4-3	February 2002			
	4-4	February 2002			
	4-5	February 2002			
	4-6	February 2002			
	4-7	February 2011			
	4-8	February 2002			
	4-9	February 2002			
	4-10	February 2002			
	4-11	February 2002			
	4-12	February 2002			
	4-13	February 2011			

#### 4.5.4 Adjustment of Backrest

**Warning:** *Adjust backrest in such way, that lower spine is well supported and not bent and lap belt can be adjusted tight.*

Two possibilities of adjustment, both can be used on the ground only

- (a) Lower adjustment allows use of various types of parachute (locating pegs and slotted screw)
- (b) Upper end slope adjustment

During adjustment, watch out for the following:

- (c) Locking pin behind main bulkhead must be fully engaged
- (d) Position head as high as possible for good visibility
- (e) Tow hook handle and other controls must be within easy reach
- (f) Remember colour code at backrest support to allow for easy position identification of personal adjustment.

**Warning:** *Moving aileron with stick fully back, the stick must not open the safety harness !*

**Warning:** *When the backrest is removed for huge pilots, then*

- (1) the guide tube must also be removed (it may obstruct an emergency exit)*
- (2) Additionally, an adjustable headrest according to drawing 3BR-101 must be installed.*

#### 4.5.5 Retractable Landing Gear

- (a) Extension or retraction permitted over whole approved speed range
- (b) Rapid operation eases retraction
- (c) Handle locked in forward position = gear up
- (d) Handle locked in rearward position = gear down

**Important Note:** **When using the C.G. hook, retract gear after releasing tow cable, because C.G. hook is fitted to landing gear fork.**

#### 4.5.6 Wheel Brake

Press rudder pedals with both feet to activate wheel brake.

**With TN8019 executed:** The wheel brake is actuated by the air brake handle, instead of by the rudder pedals.

**4.5.10.6 Dumping of Water Ballast**

- (a) Ballast lever forward = All ballast tanks open.
- (b) Discharge time about 3 Minutes, i.e. at 190 Litres <50.2 US gallons, 41.8 Imp. gallons> approx. 63 Litres <16.6 US gallons, 13.9 Imp. gallons> per minute:
  - (1) If aileron stick force is required to maintain level flight after about 3 minutes of dumping, this may indicate unequal dumping. Such **asymmetry** must be counteracted by leaving dump valves open long enough, if necessary until after landing.
  - (2) Open valves emit a buzzing sound when tank is empty.
  - (3) To avoid ground looping in case of unequal dumping, apply aileron in the direction as noticed before shortly after touchdown.

**Warning:** *Check thermometer regularly during flight. Dump water at +5° Centigrade <41°F>; ballast water in wing shell and tail tank should never freeze solid. (See also page 3-4).*

**4.5.11 Winch Launch or Auto Tow**

- (a) Trim slightly nose heavy: Trim position indicator in front of neutral-mark.
- (b) Adjust backrest properly (See page 4-7) and tighten seat belt harness to avoid sliding backwards during acceleration and steep climb.
- (c) Ask winch operator to avoid too high acceleration.  
The higher the initial acceleration, the higher the pitch-up tendency.
- (d) Use wheel brake during tightening of tow cable to avoid rolling over cable.  
**With TN8019 executed:** It's not recommended to use the wheel brake during tightening of tow cable.
- (e) Pronounced forward stick pressure is required during transition arc.
- (f) **Minimum tow speed:**

without water ballast	90 km/h <49 Kt., 56 mph>
with water ballast	100 km/h <54 Kt., 62 mph>
- (g) Retract landing gear **after** tow, because C.G. hook is fitted to landing gear fork.

**4.5.12 Aero Tow**

- (a) Aero tow must be performed at the nose hook.
- (b) Trim slightly nose heavy: Trim position indicator in front of neutral mark.
- (c) Use wheel brake during tightening of tow cable to avoid rolling over rope.  
**With TN8019 executed:** It's not recommended to use the wheel brake during tightening of tow rope.
- (d) **Minimum Tow Speed:**
- |                       |                           |
|-----------------------|---------------------------|
| without water ballast | 100 km/h <54 Kt., 62 mph> |
| with water ballast    | 120 km/h <65 Kt., 74 mph> |
- (e) Recommended tow cable length: 30 - 80 m <100 - 260 ft>

**Warning:** The C.G. hook is not approved for aero tow.

**4.5.13 Free Flight**

- Stalling speed (IAS) for straight and level flight and air brakes retracted:
 

<b>15m &lt;49 ft&gt; wing span:</b>	
Without water ballast:	<b>68-70</b> km/h <37-38 Kt., 42-43 mph>
With maximum water:	<b>82-84</b> km/h <44-45 Kt., 51-52 mph>
<b>18m &lt;59 ft&gt; wing span:</b>	
Without water ballast:	<b>65-67</b> km/h <35-36 Kt., 40-42 mph>
With maximum water:	<b>79-81</b> km/h <43-44 Kt., 49-50 mph>
- Circling flight: (Thermalling) Trim stick forces to zero.
- Best Glide Angle: between 95 to 105 km/h <51 to 57 Kt., 59 to 65 mph>
- High speed flight: Reduce stick forces by trimming. Avoid abrupt manoeuvres and check speed indication regularly to avoid exceeding limit values.

**Warning:** *Observe air speed limits versus altitude (see page 2-2)*

**Warning:** *In emergencies, air brakes can be extended up to VNE = 280 km/h <151 Kt., 174 mph> ; Extend air brakes cautiously, because in this speed range air brakes are being sucked out suddenly, causing short time negative acceleration and may initiate pilot induced oscillations (P.I.O.).*

**Warning:** *Check thermometer, when using water ballast, regularly during flight. When temperature is decreasing, dump water at least at +5° Centigrade <41° F> to ensure proper dumping and avoid structural damage at wing shell and vertical tail fin shell (Integral tanks).*

7.2 Cockpit Controls

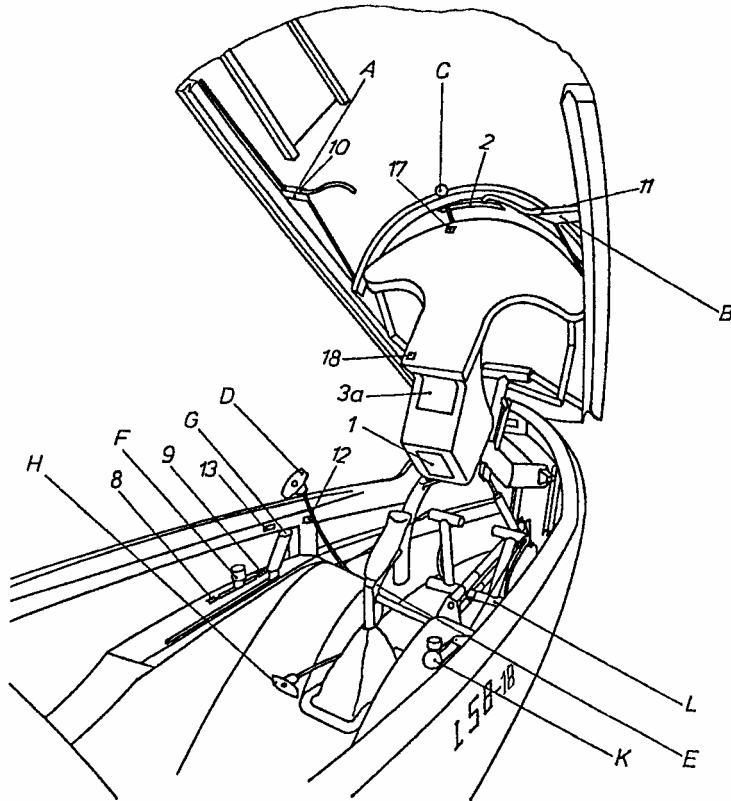

Numbers refer to placards, see also Flight Manual, pages 2-13 and Maintenance Manual pages 10-1 and 10-2.

- A - Left canopy locking
- B - Right canopy locking and emergency jettison
- C - Ventilation
- D - Tow cable release
- E - Trim locking lever
- F - Trim lever, also indicating trim position
- G - Air brake handle
- G with TN8019 executed:**  
Air brake and wheel brake
- H - Pedal adjustment
- I - Landing gear
- K - Water ballast
- L - Rudder pedals and wheel brake (feet operated)
- L with TN8019 executed:**  
Only rudder pedals
- M - Dummy lever (petrol valve)

