

## Working instruction No.1 for TNLS10-03 and TN8022

### Mechanical fuel pump

#### Replacing the mechanical fuel pump type Bing 8080 by a pump Mikuni DF44-18

See also LS10 maintenance manual diagrams 22 or 23, resp. LS8-t maintenance manual pages 10-2 or 10-2a.

1. Remove the power plant according to LS10 MM section 4.15.1, use the check list in section 9.4., resp. LS8-t MM section 4.7.1 (no checklist for LS8-t).
2. Remove the engine from the engine mount. Propeller, fuel system incl. fuel pump and electric wiring should remain at the engine and therefore must be disassembled from the engine mount. Note directions of bolts and position of cable ties, best by taking pictures.
3. Remove Bing fuel pump from the fuel lines.
4. Ship the engine mount to DG Flugzeugbau for modification of the mounting plate for the fuel pump (according to drawings M01-200 issue f and M01-234 issue c).
5. Re-install the engine to the engine mount, see also LS10 MM diagram 14 and section 1.15.8 (tightening torques and locking), resp. LS8-t MM diagram page 10-1 and section 1.9.8.  
Torque the upper engine rubber mounts so that they are compressed to a value of 27 mm (1.06 in.) see sketch.  
Install the Mikuni fuel pump with bolts, nuts and washers Pos. 2-4 to the engine mount according to the sketch below.
6. Reconnect fuel and impulse lines, re-use existing hose clamps. The line from pump to T-connector is now 90 mm long instead of 65 mm, Pos. 5.
7. Re-install the power plant to the fuselage according to LS10 MM section 4.15.2, use the check list in section 9.4., resp. LS8-t MM section 4.7.2. After re-connecting the cable for the de-compression valves check the adjustment according to LS10 MM section 1.15.7, resp. LS8-t MM section 1.9.7. Correct if necessary at the adjustment screw at the engine mount and if this is not sufficient in addition at the adjustment screw in the cockpit, see LS10 MM diagram 17, resp. LS8-t MM diagram page 10-8.
8. Perform an engine test run according to LS10 MM section 4.18 resp. LS8-t MM section 4.10 or perform the test run in flight. Run the engine at full power and position the fuel pump switch at the DEI-NT to the "on" position, then switch off the main switch for 30 seconds to shut off the electrical fuel pump. The engine must continue running and you shouldn't hear any RPM drop. Check for any leakages after the test run.

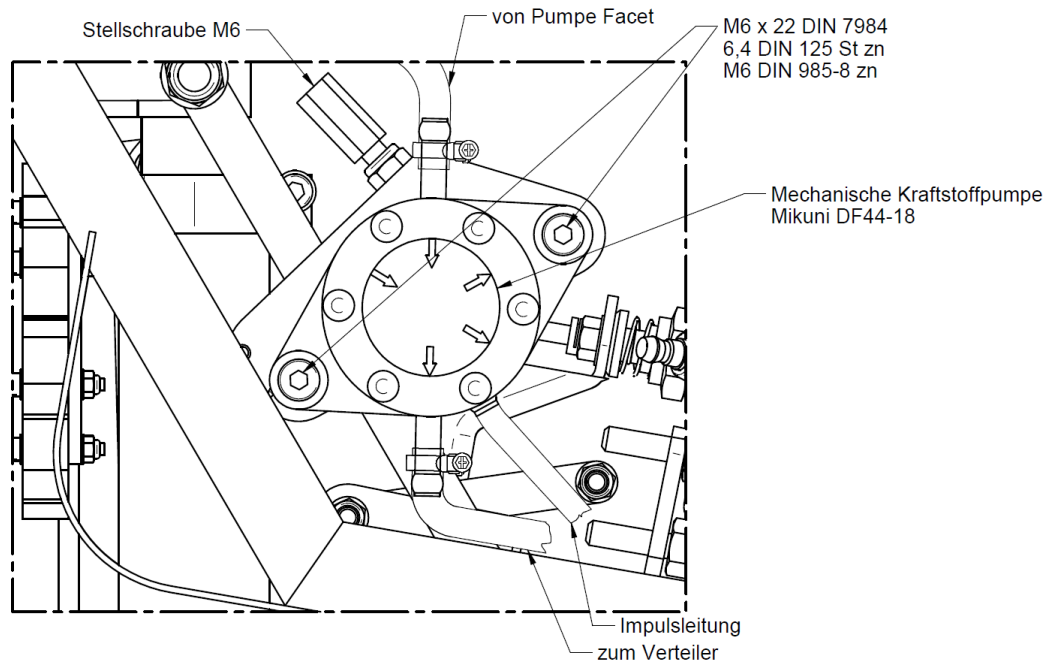
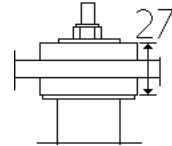

Pos.	No. of parts needed	DG part No.	Description
1	1	60500257	Mechanical fuel pump Mikuni DF44-18
2	2	50062203	M6x22 DIN7984-8.8 zn
3	2	51060020	M6 DIN985-8 zn
4	2	52060001	6,4 DIN125 St zn
5	1	60507541	Fuel hose PU 6x1,5x9 metal braided and with red heat shrink tubing at both ends, 90 mm long