

Modification of the powerplant – ignition unit to Ducati 432372501 ignition electronic boxes

Note: On the ignition boxes the no. is given without the first digit = 32372501.

A: Remove the DEI and ship for modification to Schicke Elektronik GmbH (address on page 5)

Warning: Without DEI modification the powerplant will be damaged.

B: Remove the ignition electronic boxes, they will not be used again.

C: Modification of the wiring

1. Open the cable harness from the ignition boxes up to the cable junction (pic.2 and sketch 2). The wires coloured white, brown, black and red are for ignition box 1 and white/red, brown, black and red are for ignition box 2.
2. Cut the white and the white/red wire 40 mm (sketch 2 detail Z) in front of the junction of the cable harness (pic.2). Slip pieces of heat shrink tubing over the shortened wires, crimp one spade connector (female) to each of the wires and shrink the tubing.
3. Plug an ignition box filter (pict. 1) to each of the two cable shoes. Slip heat shrink tubing over the connections and shrink the tubing. Take care of the correct mounting direction. (see pict.2).
4. Crimp a spade connector (male) on each of the wires remaining from point 2. Connect the wires according to pict.2 to the filters, so that you have the same wire colours as on the other side of the filter.
5. The cable harness for the ignition box aft (BOX II) has to be shortened to 300mm (pic.2). The cable harness for the front ignition box (BOX I) has to be shortened to 220mm (sketch 2 and pic.2). Slip heat shrink tubing over the cable harness as indicated in picture 2 and shrink the tubing. Note: 20mm of the wires must not be covered by the heat shrink tubing see pict.2.
6. Crimp cable shoes to the wires according to pict.2
7. Connect the wires to the ignition boxes according to pict.2.
8. Slip heat shrink tubing over every connection.
9. Cover the cable harness completely with heat shrink tubing.
10. The cable harness has to be fixed. The cable harness should not be able to vibrate or rub. Fix the cable harness according to pic3, 4 and 5 and drawing 4M77. The ty-raps have to be tightened by hand as tight as possible.
11. Move the Bowden cable mounting 4R38/1 60 mm from the original position to the position (see sketch 1). This must be done even when Ducati boxes have already been installed.

D Install the DEI again, perform engine test run.

necessary material:

pieces	Description
1	Service kit No.21000124

consisting of

piece	description	piece	description
2	Ducati 432372501 ignition boxes	4	washer 6,4 DIN9021
2	ignition box filter 4E28	2	nut M6 DIN985
20	Ty-raps 3,6x140	700mm	heat shrink tubing 1/2" FT500
12	male spade connector RSQ 7610 6,1-1	600mm	heat shrink tubing 19-9,5 FT5550
12	female spade connector RSQ 7600 A 6,3-1	700mm	heat shrink tubing DERAY H 1/4"



Picture 1

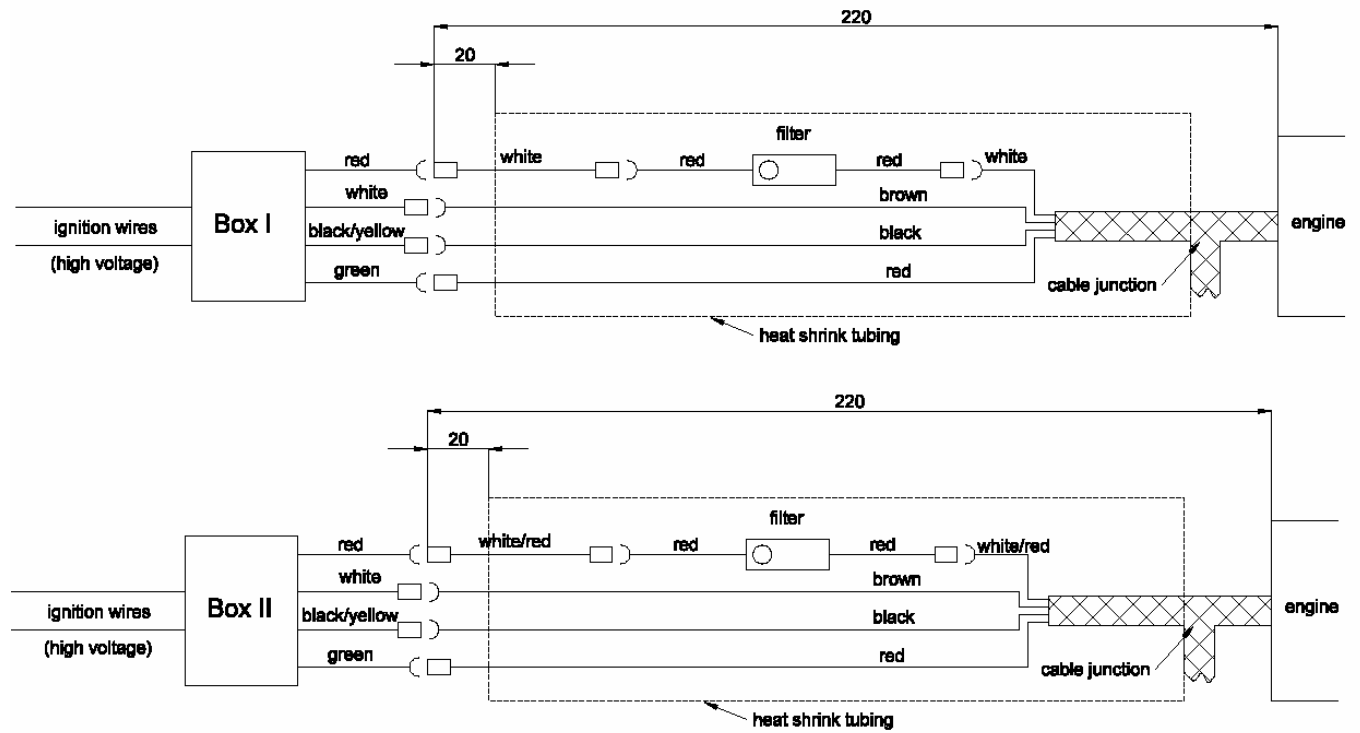

Picture 2

Warning: don't mix up the wire colours!



Picture 3



Picture 4



Picture 5

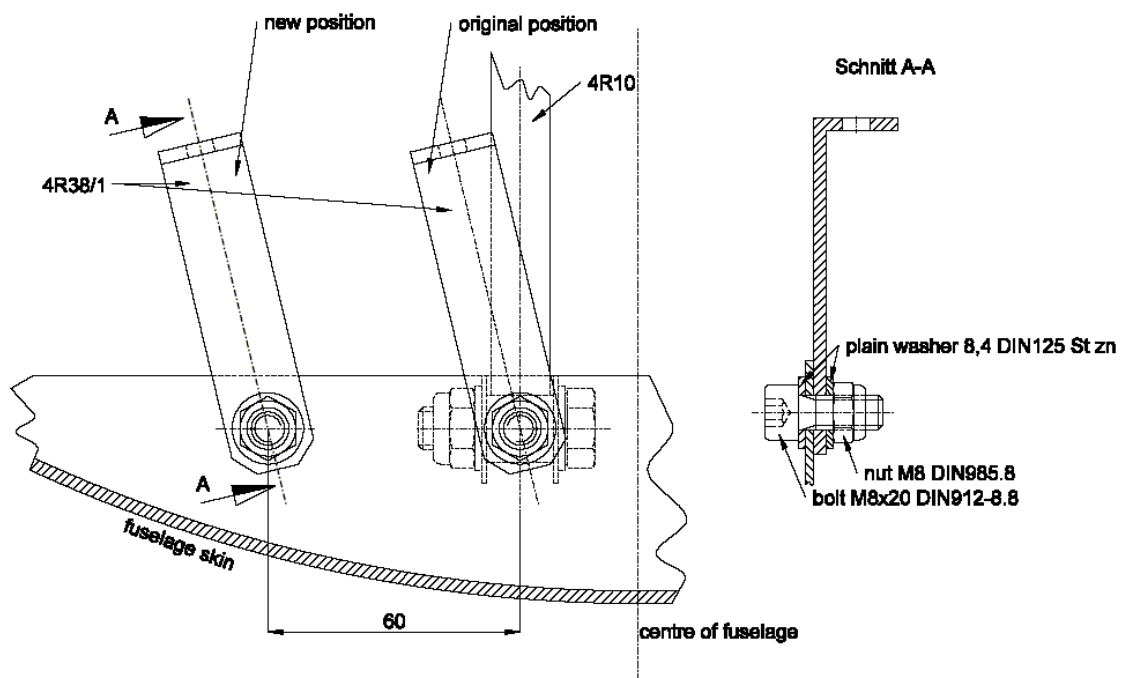

Sketch 1

Issued: August 23.2006

Revision 1: 12. February 2010

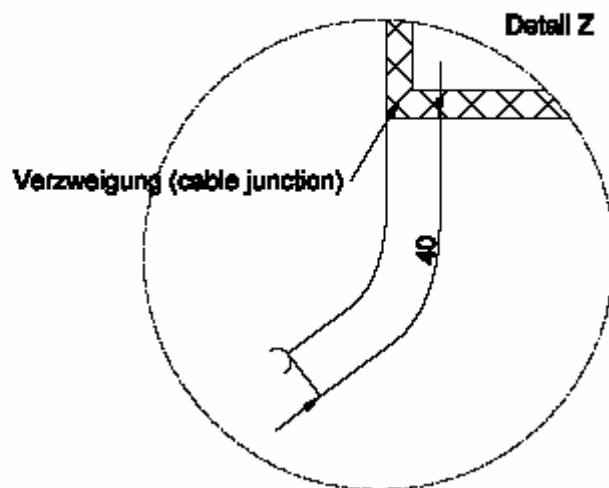
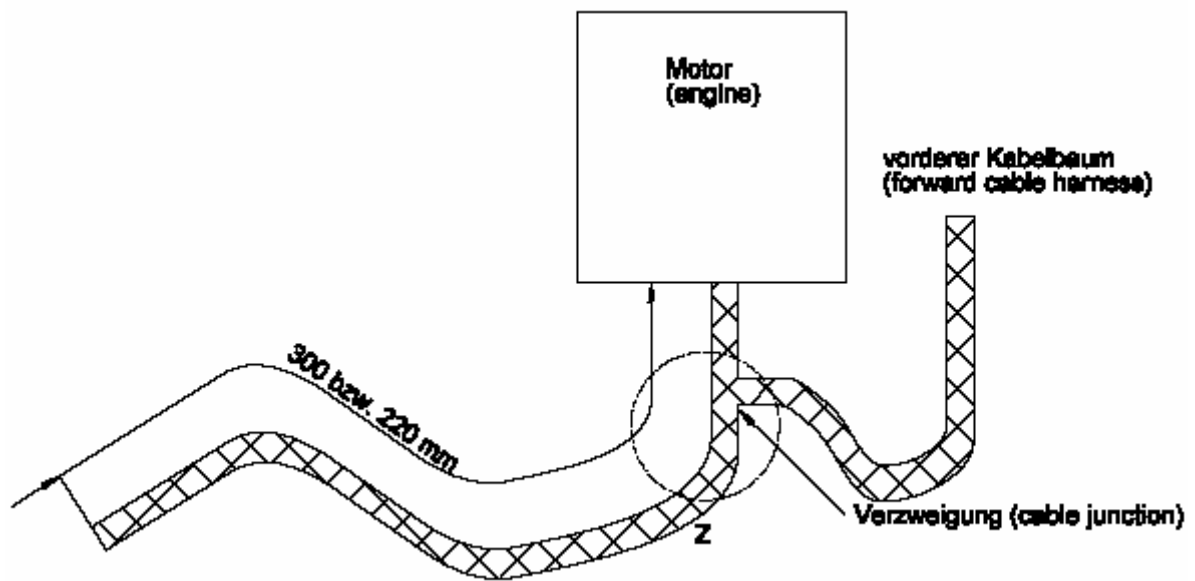

Sketch 2

Address to ship the DEI:
Schicke Elektronik GmbH
Kanalstraße 32

D-76356 Weingarten
Germany