

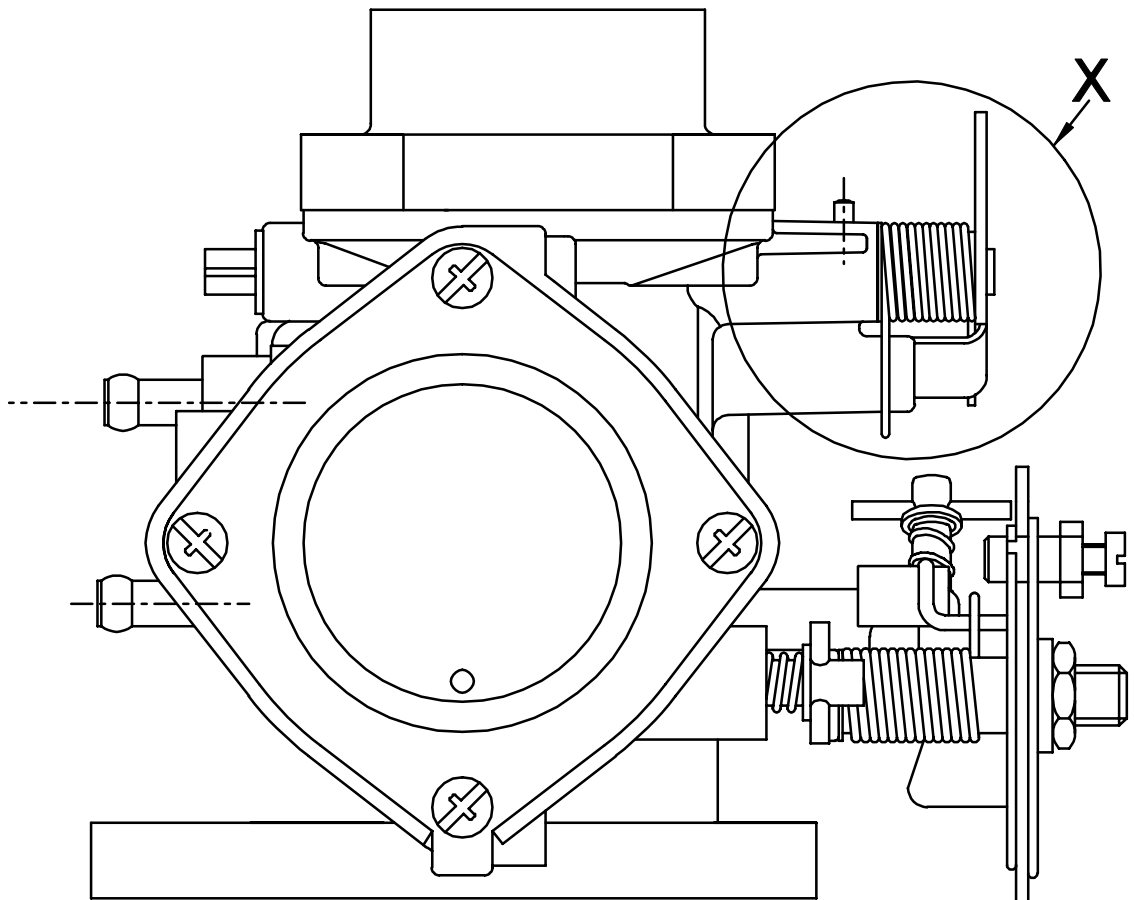

← direction of flight

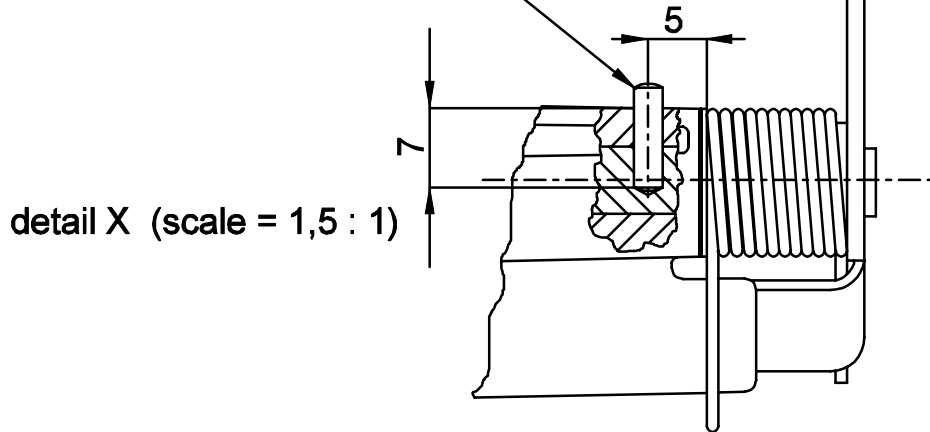

drill-hole dia. 2,5 mm  
notched taper pin 2,5 X 10 DIN 1471  
secured with Loctite 243



detail X (scale = 1,5 : 1)

Toleranzen nach Arbeitsanweisung BA 1					Tag	Name	<b>DG</b> <b>Flugzeugbau GmbH</b> 76646 Bruchsal Otto-Lilienthal-Weg 2
Schweißen nach Arbeitsanweisung SA 1					Gez.	28.09.01 Nico Polzin	
					Gepr.		
					Norm.		
					Maßstab	<b>Carburettor BN 38</b> <b>new version</b> <b>blocking the choke axis</b>	 <b>8M303</b>
					1:1		
					1,5:1		
					Maße ohne Toleranzang. nach:		
Ausg.	Änderung	ÄM	Tag	Name			