

Flight manual DG-500/22 ELAN

0.1 Record of revisions

Any revision of the present manual, except actual weighing data, must be recorded in the following table and in case of approved sections endorsed by the responsible airworthiness authority.

The new or amended text in the revised page will be indicated by a black vertical line in the right hand margin, and the Revision No. and the date will be shown on the bottom left hand of the page.

Rev. No.	Affected pages / section	Description	Issue Date	LBA Approval Date	Inserted Date Signature
1	0.3, 4.11	TN 348/1S	Mar. 92	31.03.92	
2	0.4,7.2	TN 348/3S	Oct. 92	08.12.92	
3	0.3, 0.4, 1.2, 2.5, 4.3, 5.2, 5.5, 6.2, 6.5, 6.7, 6.9, 7.1, 7.9, 7.10	TN 348/9	Oct. 97	26.11.97	
4	0.3, 0.4, 4.7, 7.7, 8.2	TN 348/15	Jan. 01	07.02.01	
Rev. No.	Affected pages / section	Description	Issue Date	EASA Approval Date	Inserted Date Signature
5	0.3, 0.4, 2.6, 3.1-3.4, 4.1, 4.7, 4.15, 7.1, 7.7, 7.8	TN 348/20 manual revision	May 2008	August 1. 2008	
6	0.3, 0.4, 9.1, 9.2	Special equipment for very small pilots TN500/02	May 2010	20.07. 2010	
7	0.1, 0.3, 0.4, 4.7, 4.8, 7.1, 7.10	TN500/13 Canopy lock, rear locking rods	July 2019	17.09. 2019	

0.2 List of effective pages

<u>Section</u>		<u>page</u>	<u>issued</u>	<u>replaced</u>	<u>replaced</u>
0		0.0	May 90		
		0.1	See record of revisions		
		0.2	See record of revisions		
		0.3	See record of revisions		
		0.4	See record of revisions		
		0.5	May 90		
1		1.1	"		
		1.2	Dec.90	Oct. 97	
		1.3	May 90		
		1.4	"		
		1.5	"		
2	App.	2.1	"		
	"	2.2	"		
	"	2.3	"		
	"	2.4	"		
	"	2.5	"	Oct. 97	
	"	2.6	"	May 08	
	"	2.7	"		
	"	2.8	"		
	"	2.9	"		
3	"	3.1	"	May 08	
	"	3.2	"	May 08	
	"	3.3	"	May 08	
	"	3.4	"	May 08	
4	"	4.1	"	May 08	
	"	4.2	"		
	"	4.3	"	Oct. 97	
	"	4.4	"		
	"	4.5	"		
	"	4.6	"		
	"	4.7	"	Jan. 01	May 08
				July 19	
	"	4.8	"	July 19	
	"	4.9	"		
	"	4.10	"		
	App.	4.11	"	March 92	
	"	4.12	"		
	"	4.13	"		
	"	4.14	"		
	"	4.15	"	May 08	
"	4.16	May 90			

0.2 List of effective pages (cont.)

<u>Section</u>		<u>page</u>	<u>issued</u>	<u>replaced</u>	<u>replaced</u>	<u>replaced</u>
5	"	5.1	May 90			
	"	5.2	"	Oct. 97		
	"	5.3	"			
	App.	5.4	"			
		5.5	"	Oct. 97		
		5.6	"			
		5.7	"			
6		6.1	"			
		6.2	"	Oct. 97		
		6.3	"			
		6.4	"			
		6.5	"	Oct. 97		
		6.6	"			
		6.7	"	Oct. 97		
		6.8	"			
		6.9	"	Oct. 97		
7		7.1	"	Oct. 97	May 08	July 19
		7.2	"	Oct. 92		
		7.3	"			
		7.4	"			
		7.5	"			
		7.6	"			
		7.7	"	Jan. 01	May 08	
		7.8	"	May 08		
		7.9	"	Oct. 97		
		7.10	Oct. 97	July 19		
8		8.1	May 90			
		8.2	"	Jan. 01		
		8.3	"			
		8.4	"			
		8.5	"			
9		9.1	May 90	Mai 10		
		9.2	May 10			

B Inspection after rigging

Walk around the aircraft

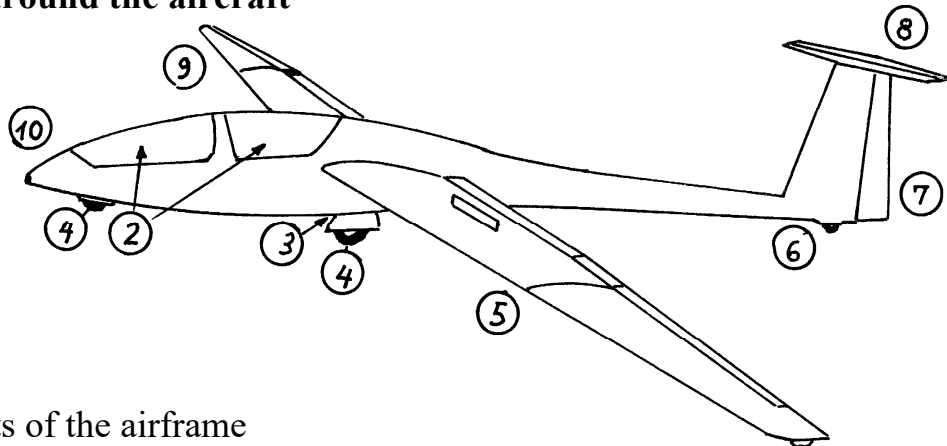

1. All parts of the airframe
 - a) check for flaws such as bubbles, holes, bumps and cracks in the surface
 - b) check leading and trailing edges of the wings and control surfaces for cracks
2. Cockpit area
 - a) check the canopy locking mechanism
 - b) check the canopy emergency release see sect. 7.15 (not each day, but min. every 3 month)
 - c) check the main pin securing
 - d) check the securing ropes of the headrest in the rear cockpit for wear function and length: is it possible that the headrest interferes with the control stick?
 - e) check all controls for wear and function, incl. positive control check
 - f) check the tow release system for wear and function incl. cable release check
 - g) check for foreign objects
 - h) check the instrumentation and radio for wear and function
 - i) check the radio and other electrical equipment for function. If there is no electric power it must be assumed, that the battery is not installed in the fin. **Flying is only allowed with the battery in the fin as otherwise the forward C.G. limit may be exceeded.**
 - j) check the brake fluid level
 - k) check at front and rear canopy if the end of the rear locking rod doesn't protrude over the canopy frame contour with opening mechanism in fully open position.
If the rod protrudes over the contour proceed with instruction 3 of TN 1000/42.
 - l) Option Canopy warning: Check if with front canopy locked and rear canopy open a warning burr appears. If not you have to exchange the battery, see section 7.16.5.

Flight manual DG-500/22 ELAN

3. C.G. Tow hook
 - a) check the ring muzzle of the C.G. hook for wear and function
 - b) check for cleanliness and corrosion
4. Main landing gear and nose wheel
 - a) check the struts, the gear box, the gear doors and the tyre for wear; dirt in the struts can hinder the landing gear from locking over center the next time!
 - b) check the tyre pressure
mainwheel: 3.0 bar - 44 psi
nose wheel: 2.5 bar - 36 psi
 - c) check wheel brake and cable for wear and function
5. Left wing
 - a) check locking of the outboard wing
 - b) check the aileron for excessive free play
 - c) check the wing flaps for excessive free play
 - d) check airbrake- and box and control rod for wear and free play. It must be possible to retract the airbrake, even if it is pressed in backward direction. If there is any water in the airbrake box this has to be removed.
 - e) check the locking of the rear wing attachment pin
6. Tail wheel
 - a) check for wear, free play and excessive dirt in the wheel box. Remove excessive dirt prior to take off!
 - b) check tyre pressure: 4 bar -58 psi
7. Rear end of the fuselage
 - a) check the lower rudder hinge and the connection of the rudder cables for wear, free play and correct securing
 - b) check the bulkhead and fin trailing edge shear web for cracks and delamination
8. Fin - horizontal tail
 - a) check the upper rudder hinge for wear and free play
 - b) check the elevator for free play and correct control hook up, look from the rear into the gap at the right hand side of the rudder c) check the securing of the stabilizer
 - d) check the horizontal tail for free play
 - e) check the TE or Multiprobe for correct insertion
9. Right wing see detail 5.
10. Fuselage nose
 - a) check the ports for the static pressure and the pitot pressure for cleanliness.
 - b) if the sailplane was parked in rain, you have to empty the static ports by sucking out the water at the ports.
 - c) check the nose hook for cleanness and corrosion

Flight manual DG500/22 ELAN

Section 7

- 7. Sailplane and systems description
 - 7.1 Introduction
 - 7.2 Airframe
 - 7.3 Cockpit, cockpit controls and placards
 - 7.4 Flight controls
 - 7.5 Airbrake system
 - 7.6 Landing gear system
 - 7.7 Tow hooks
 - 7.8 Seats and safety harness
 - 7.9 Baggage compartment
 - 7.10 Water ballast system
 - 7.11 Section not effective
 - 7.12 Section not effective
 - 7.13 Electrical system
 - 7.14 Pitot and static system
 - 7.15 Canopies
 - 7.16 Miscellaneous equipment (Options)
 - 7.16.1 Removable ballast
 - 7.16.2 Oxygen system
 - 7.16.3 ELT
 - 7.16.4 Heavy tailwheel
 - 7.16.5 Canopy warning

Flight manual DG500/22 ELAN

Caution: Concerning 7.16.3 and 7.16.4

The installation of such equipment has to be accomplished by the aircraft manufacturer or by an approved service station and to be inspected and entered in the aircraft log book by a licensed inspector.

7.16.4 Heavy tailwheel

Instead of the standard tailwheel with plastic hub a tailwheel with brass hub S 27/1 may be installed. The installation kit S 27/4 is available at DG-FLUGZEUGBAU GmbH.

The difference in mass between both hubs is 3.1 kg (6.84 lbs). With the brass hub, the min. front cockpit load is increased by 8.5 kg (18.74 lbs).

This higher value must be entered in the cockpit data placards and on page 6.5. Even if the heavy tailwheel is installed only sometimes, the higher min. cockpit load must be entered.

7.16.5 Canopy warning

Optionally a canopy warning device may be installed according to drawing 5EP36.

This device warns by a buzzer if the front canopy is locked and the rear canopy is still not locked or open. The buzzer is installed at the bow between front and rear canopy at the right hand side. The battery is a Lithium button cell 2430 3V/200m Ah. It is soldered and glued to the buzzer.