

Installation of an additional bracket 5St122

1. Derig the glider and remove the baggage compartment floor and back cover plate
2. Instruction 2 of TN348/19 according to working instruction No. 2 for TNM 348/19 must be executed first..
3. Identify the bellcrank 5St19 referring to diagram 1 of the maintenance manual. Remove the bellcrank.
4. Grind the gluing surfaces for part 5St122 at the bearing stand 5RU61 according to drawing 1 with abrasive paper 120 grit.
5. Grind the flanges of part 5St122 at all sides with abrasive paper 120 grit.
6. Install the bracket according to drawing 1 for a trial fit. Rotate the bracket so that the bellcrank has the same free play to the bracket in the full nose down and taildown control positions. Mark this position on the bearing stand and remove the bracket.
7. Apply pure epoxy resin/hardener to the sanded areas at the bearing stand first. Then apply resin/hardener mixed with cotton flocks approx. 2 mm thick.
8. Install the bracket according to drawing 1 in the marked position. The gap between the flanges of the bracket and the bearing stand must be filled with resin/cottonflock-mixture.
9. Fix the flanges with 2 layers of glassfibre fabric 92125 $\pm 45^\circ$ 25 x 50 mm (1 in. x 2 in.) wide to the bearing stand 5RU61.
10. Let cure at room temperature for min. 12 hours.
11. Postcure for min. 18 hours at min. 54°C (130° F).
12. In case the bolt is so short that the bolt end doesn't protrude min. 1 mm (.04 in.) out of the securing ring of the self locking nut, additionally secure the nut with Loctite 243 or 638. Mark the Loctite secured nut with a line of red securing paint which also marks the part 5St122.
13. Retorque the nut with a torque wrench with a value of 12 Nm(9 ft. lb.)
14. Execute a control check.
15. Reinstall the baggage compartment floor and back cover plate..

necessary material:

1 bolt M6x44 LN9037

1 selflocking nut M6 DIN985-8zn or M6 LN9348

1 bracket 5St122

Epoxy resin with hardener according to the list in the repair manual

Cottonflocks

Glassfibre fabric Interglas 92125

Issued: 25.06.2007

Revision a: Correction item 12 28.01.2008

Author: Dipl. Ing. Wilhelm Dirks

drawing No. 1

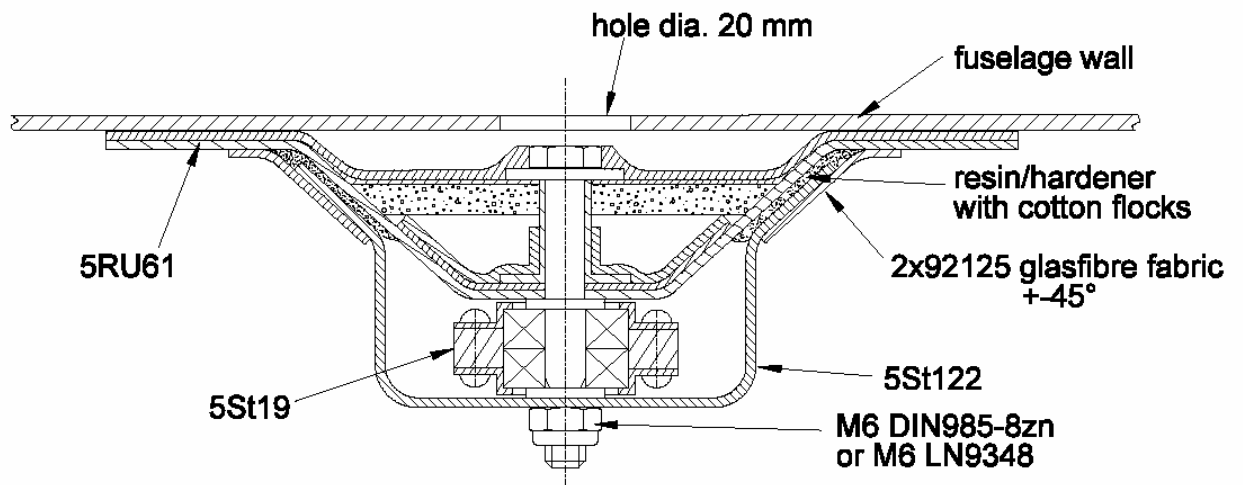
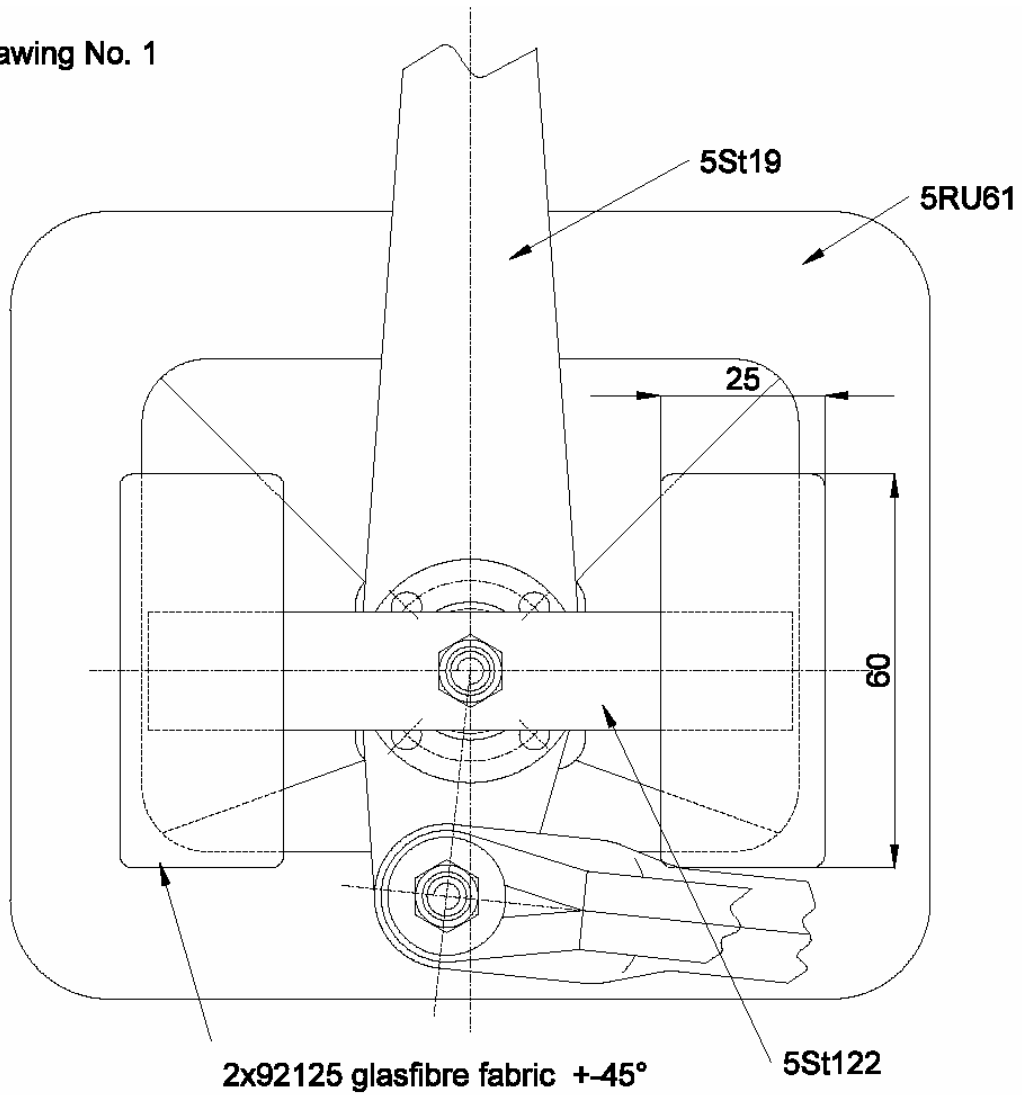

Issued: 25.06.2007

Revision a: Correction item 12 28.01.2008

Author: Dipl. Ing. Wilhelm Dirks