

No. 301/23
323/14
359/21
826/44

No. 348/18
843/21
370/9
866/10

- Subject : Lower mounting of the rudder
- Effectivity : DG-100, DG-200, DG-300, DG-400, all models and all ser.no.'s
DG-500, DG-500M all models up to 5E23
DG-600, DG-600M all models and all ser.no.'s.
- Accomplishment : Instruction 1 with every daily inspection until instruction 3 has been executed.
Instruction 2: if necessary
Instruction 3: up to Dec. 31.2004
- Reason : On a DG-100 the universal bearing of the lower rudder mounting slipped out of the bearing support and the rudder fell out.
As the design is similar on all DG-types this kind of failure may occur on all DG's.
On later models this connection was secured by an extra securing washer.
Such a washer must be retrofitted to all DG-types with this TN.
- Instructions
1. Check if the outer bearing ring is correctly in place in the rudder mounting, the ring should not be visible.
 2. If the bearing is out of place the rudder mounting must be removed and the bearing must be secured by peening with a chisel or the complete rudder mounting must be exchanged. In addition execute instruction 3 at the same time.
 3. Check if a securing washer (min. outside diameter 18mm, 0.71 inch) is installed according to the sketch.
 - a) If yes: The execution of this TN can be entered in the aircraft logs by a licensed inspector without further work to be done.
 - b) If no: Remove the castellated nut, install the washer 8.4 DIN9021 and reinstall the nut.
 1. Check if the washer is interfering with the rudder mount. If yes, use a washer 6,4DIN9021 St zn instead, enlarge the 6mm hole to 8mm to enable installation.
 2. Check if the split pin can be installed. If yes, secure with a new split pin 2x20 DIN94 zn.If this is not possible, mark the position for a new hole and remove the rudder. Drill a new hole (diameter 2mm, .08 inch) 90° to the existing hole. Reinstall the rudder, use new split pins.

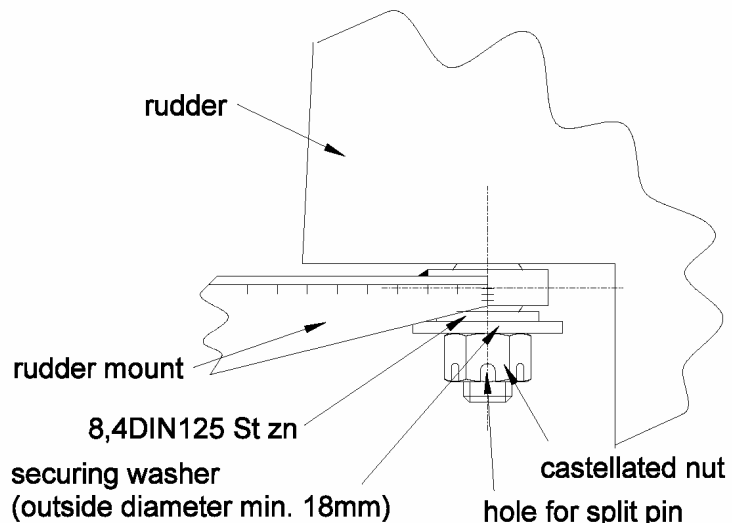

No. 301/23 issue 2	No. 348/18 issue 2
323/14 issue 2	843/21 issue 2
359/21 issue 2	370/9 issue 2
826/44 issue 2	866/10 issue 2

Material : 1 washer 8,4 DIN9021 St zn, or 6,4DIN9021 St zn hole enlarged to 8mm
1 split pin 2x20 DIN94 zn
2 split pins 1,5x12 DIN94 zn
If necessary lower rudder mounting:
DG-100, DG-200: L14
DG-300, DG-400: 4L14
DG-500: 5L9
DG-600: 6R14

Weight and balance : influence negligible

Remarks : Instructions No. 2 and 3 are to be executed by the manufacturer or by a licensed workshop and to be inspected and entered in the aircraft logs by a licensed inspector.

Bruchsal, date: LBA – approved:
June 11. 2004
Amended July7. 2004

Author: The German original of this TN has been approved by the LBA under the date of
Dipl. Ing. Wilhelm Dirks 8. July 2004 and is signed by Mr. Blume.



The translation into English has been done by best knowledge and judgement.

Type certification EASA approved on 13. July 2004 under Approval No. 2004-7474
inspector:
Dipl. Ing. Swen Lehner

