

### Modification of the engine ignition unit to Ducati 432372501 ignition electronic boxes

1. Remove ignition boxes with securing plates 4M33, mounting plate for boxes 4M9,, propeller brake lever 4M16 and the securing plates for the spark plugs 4M34.

Caution: When removing the securing plates hold the cylinderhead nuts with a flat special spanner W33.

Pull off the spark plug connectors and remove the spark plugs, install BR8ES spark plugs.

**Note:** The ignition boxes with securing plates 4M33 and mounting plate 4M9, spark plugs and spark plug connectors with securing plates for the spark plugs 4M34 and propeller brake lever 4M16 will not be used any more.

2. The spark plug connectors have to be exchanged for NGK TB 05 EMA. The ignition (high voltage) wires must have the following lengths see also drawing 4M77. If necessary shorten the wires after removing the spark plug connectors.

spark plug	length of wire	cylinder
1	336	front
2	336	''
3	375	rear
4	315	''

3. Modify the lower mounting plate of the engine 4M7 in the region of the spark plug connector according to the sketch below. It is not necessary to paint this region after modification.

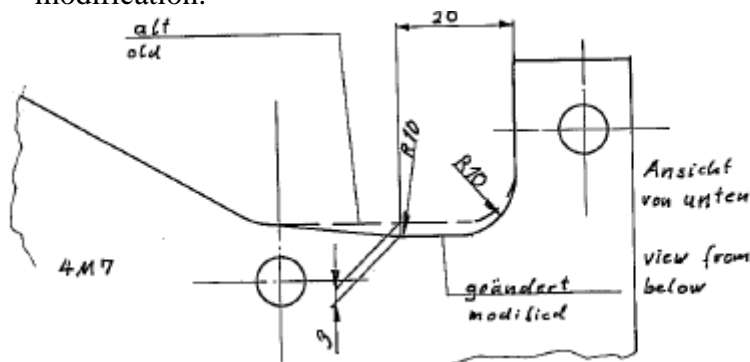

To execute this work the engine should be removed from the plate 4M7 and rotated 90° to the front.

Please refer to sect. 4.12 of the DG-400 maintenance manual for this procedure.

Protect the spindle drive against dirt.

4. Install a new mounting plate 4M72 for the ignition boxes and the propeller brake and a new brake lever 4M74/1 with bushes 4M74/2 and 3.
5. Mount the ignition boxes and the propeller brake according to drawing 4M71.
6. Change the wiring loom according to working instruction no. 2.
7. Install the wiring according to drawing 4M77.

Secure the ignition (high voltage) wiring at the 2. and 4. cylinder head nut with bolts 4M76 and ty-raps according to drawing 4M71.

Note: Don't secure the bolts 4M76 with Loctite. Only secure with counternuts M8 DIN936-8.

8. Check the ignition timing according to the maintenance manual sect. 4.16.1
9. Accomplish a test run with magneto check

**Tightening torques and securing methods:** Please refer to maintenance manual DG-400 section 1.9.10 resp. 1.10.10 for MM from issue date December 2009 on.

#### Necessary material

piece	description
1	Service kit Art. No. 21000120

containing of

piece	description	piece	description
2	Ducati 432372501 ignition boxes	2	nut M6 DIN985-8 zn
2	ignition box filter 4E28	20	Ty-raps 3,6x140
4	spark plug connectors NGK TB 05 EMA	7	Ty-raps 4,8x186
4	spark plug BR8ES	12	male spade connector RSQ 7610 6,1-1
1	4M73	12	female spade connector RSQ 7600 A 6,3-1
1	4M74/3	700mm	heat shrink tubing 1/2" FT500
2	4M76	600mm	heat shrink tubing 19-9,5 FT5550
3	spacer nut M8x50	700mm	heat shrink tubing DERAY H 1/4"
2	washer 4,3 DIN9021 St zn	1	4M72
2	screw M4x16 DIN933-8.8 zn	1	4M74/1
2	nut M8 DIN936-8 zn	1	4M74/2
2	screw M6x35 DIN912-8.8 zn		
4	washer 6,4 DIN9021 St zn		

Enclosures: drawings 4M71, 4M76, 4M77

Bruchsal, July 31.2006