

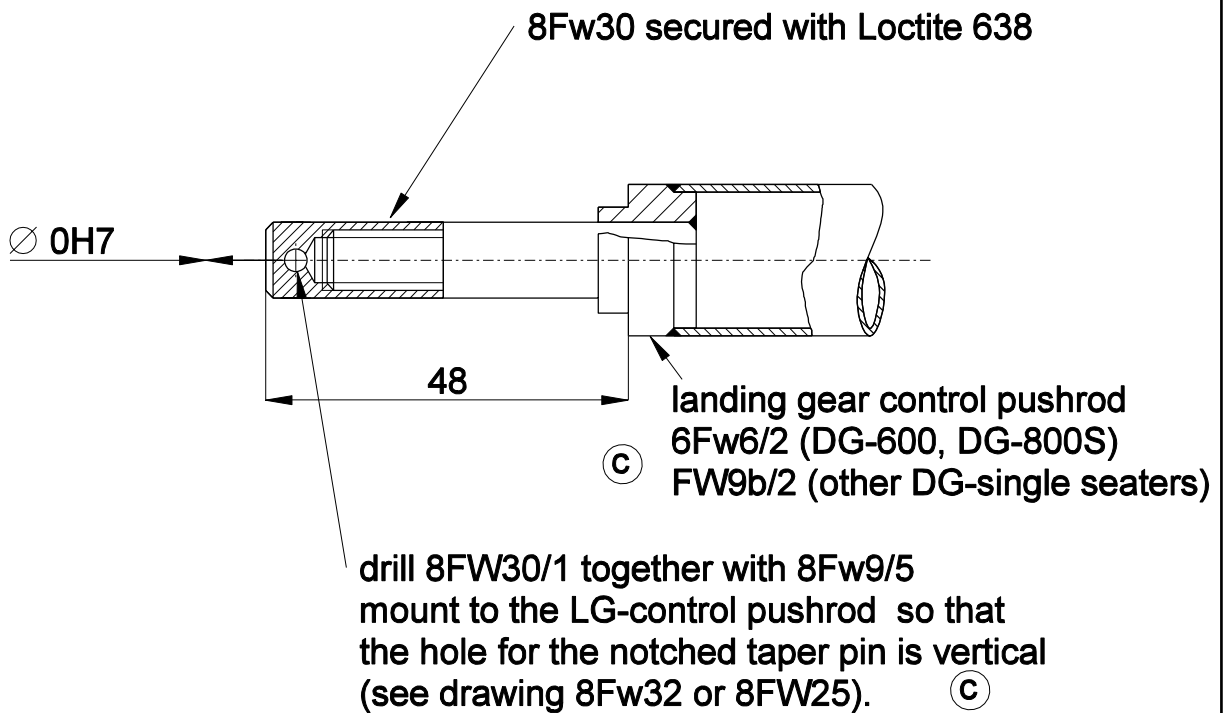

Teil 1	Stück 1
Oberflächenschutz: verchromt	
Werkstoff: 1.7734.4	



Toleranzen nach Arbeitsanweisung BA 1					Tag	Name	DG Flugzeugbau GmbH 76646 Bruchsal 4 Im Schollengarten 20
Schweißen nach Arbeitsanweisung SA 1					Gez.	08.06.98 S. Lehner	
					Gepr.		
					Norm.		
					Maßstab	Modification of the LG-control to secure handle with spring	 8Fw30
					1:1		
					Maße ohne Toleranz- ang. nach:		
c	amended	18.06.04	W.Dirks				
Ausg.	Änderung	ÄM	Tag	Name			