

## Maintenance Manual DG-1000M

No.	Page	Description	Date
11	0.2, 0.5, 0.6, 6.1, diagrams 7 + 20	Drive belt tensioning bolt, manual revision TM1000/40	September 2018

## Maintenance Manual DG-1000M

### List of effective pages (cont.)

Section	page	issued	replaced	replaced	replaced
4	4.1	October 2010			
	4.2	"			
	4.3	"			
	4.4	"			
	4.5	"			
	4.6	"	October 2012		
	4.7	"	October 2012		
	4.8	"	October 2012		
	4.9	"			
	4.10	"			
	4.11	"	October 2012		
	4.12	"	October 2012	July 2015	
	4.13	"			
	4.14	"			
	4.15	"			
	4.16	"			
	4.17	"			
	4.18	"			
	4.19	"	October 2012		
	4.20	"	October 2012		
	4.21	"	October 2012		
	4.22	"	October 2012		
	4.23	"	October 2012		
	4.24	"	October 2012		
	4.25	"	March 2016		
	4.26	"	October 2012		
	4.27	"	October 2012		
	4.28	"			
	4.29	"	October 2012		
	4.30	"	October 2012		
	4.31	"			
	4.32	"			
	4.33	"			
	4.34	"			
5	5.1	October 2010			
	5.2	"			
6	6.1	October 010	October 2012	September 18	
	6.2	"	October 2012		
	6.3	"			
	6.4	"	October 2012		

## Maintenance Manual DG-1000M

### List of effective pages (cont.)

Section	page	issued	replaced	replaced	replaced
7	7.1	October 2010	March 2016		
	7.2	October 2012	March 2016		
8	8.1	October 2010	October 2012	July 2017	
	8.2	"	October 2012	July 2014	July 2015
			July 2017		
	8.3	"	October 2012	July 2014	July 2015
		March 2016			
	8.4	"	October 2012		
	8.5	July 2014			
9	9.1	October 2010			
	9.2	"			
	9.3	"			
	9.4	"			
	9.5	"			
	9.6	"			
<b>Diagram</b>		issued	replaced	replaced	replaced
1	October 10				
2	October 10	October 2012	March 2016		
3	June 05	October 2012			
4	Nov. 01				
5	October 10				
6	October 10				
7	October 10	October 2012	Dec. 2017	March 2018	September 2018
8	October 10				
9	October 10				
10	October 10	July 2017			
11	October 10				
12	October 10	July 2017			
13	October 10				
14	October 10	July 2017			
15	October 10	October 2012	Dec. 2017		
16	October 10	October 2012	July 2015		
17	October 10				
18	October 10				
19	October 10				
20	October 10	September 18			
21	October 10				
22	October 10				
23	October 10	October 2012	July 2017		
24	October 10				
25	October 10				
26	October 10				
27	October 10				

# Maintenance Manual DG-1000M

## 6 Instrumentation and accessories list

### 6.1 Air speed indicator

(range : 0 - 300 km/h, 165 kts)

<b>Manufacturer</b>	<b>Type</b>	<b>Certification No.</b>
Winter	6 FMS 4(diam. 80mm)	TS 10.210/15
	0-300 km/h Ident.No. 6421567	
	0-160 kts Ident.No. 6423567	
Winter	7 FMS 4(diam. 58mm)	TS 10.210/19
	0-300 km/h Ident.No. 7421567	
	0-160 kts Ident.No. 7423567	

The airspeed indicator must have colour coded speed ranges marked as indicated in the flight manual section 2.3.

### 6.2 Altimeter

<b>Manufacturer</b>	<b>Type</b>	<b>Certification No.</b>
Winter	4 FGH 10 (diam. 80mm)	TS 10.220/46
	1.000-10.000m Ident.No.4110	
	1.000-20.000ft Ident.No.4320	
Winter	4 FGH 20 (diam.58mm)	TS 10.220/47
	1.000-10.000m Ident.No.4220	
Winter	4 FGH 40 (diam.58mm)	TS 10.220/48
	1.000-20.000ft Ident.No.4550	

Or any other TSO C 10b specified and approved altimeter with fine range pointer 1 turn max. 1000 m, 3000 ft.

### 6.3 Harness (seat)

<b>Manufacturer</b>	<b>Type</b>	<b>Certification No.</b>
Gadringer	BAGU 5202 G	40.070/32
	SCHUGU 2700 G	40.071/05
	rubber coated adjuster bars	
	alternatively BAGU 5202	40.070/32
Schroth	SCHUGU 2700	40.071/05
	from manufacturing year 2000 on	
	4-01-0.104	40.073/11

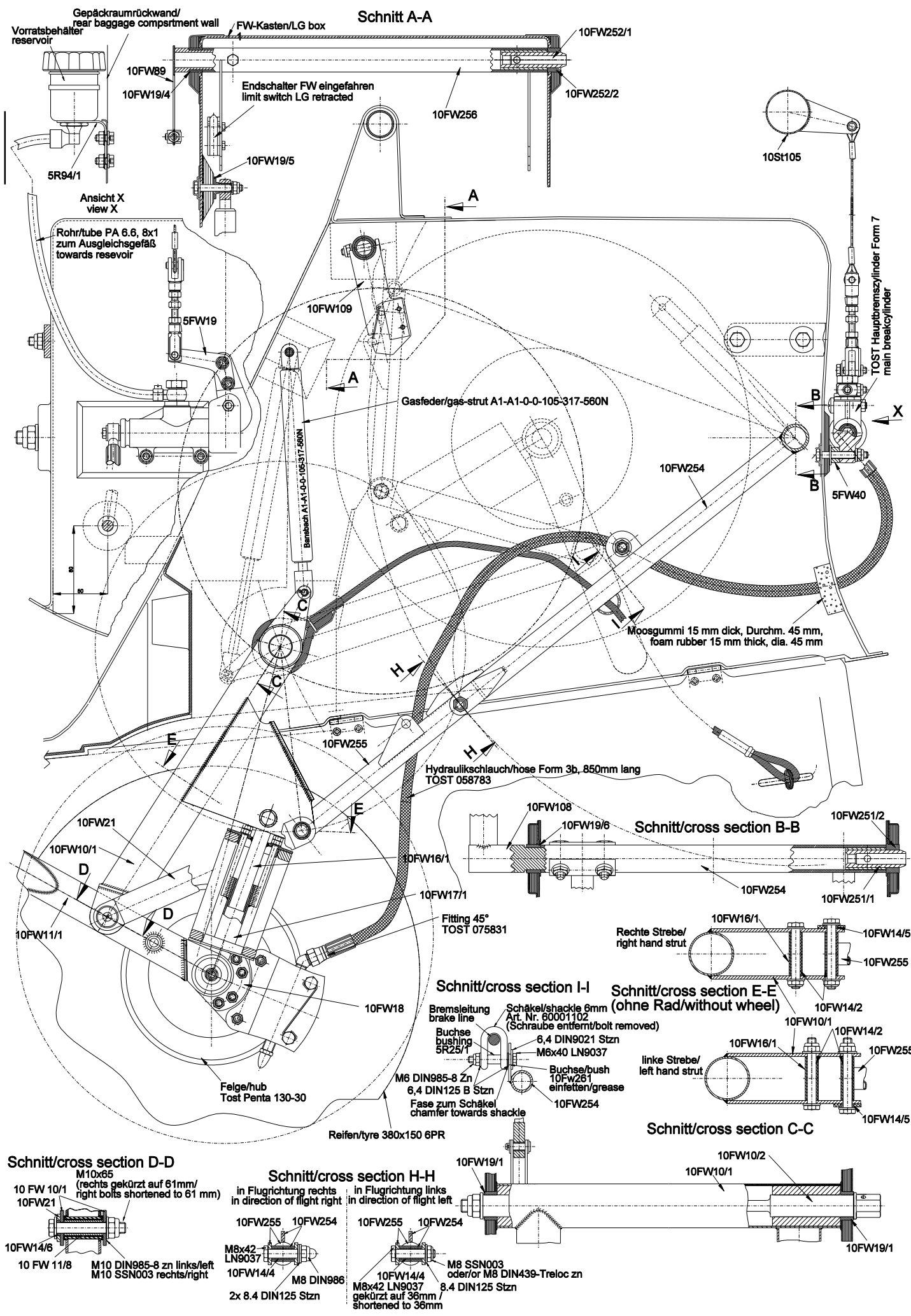

# Schnitt / Cut A-A

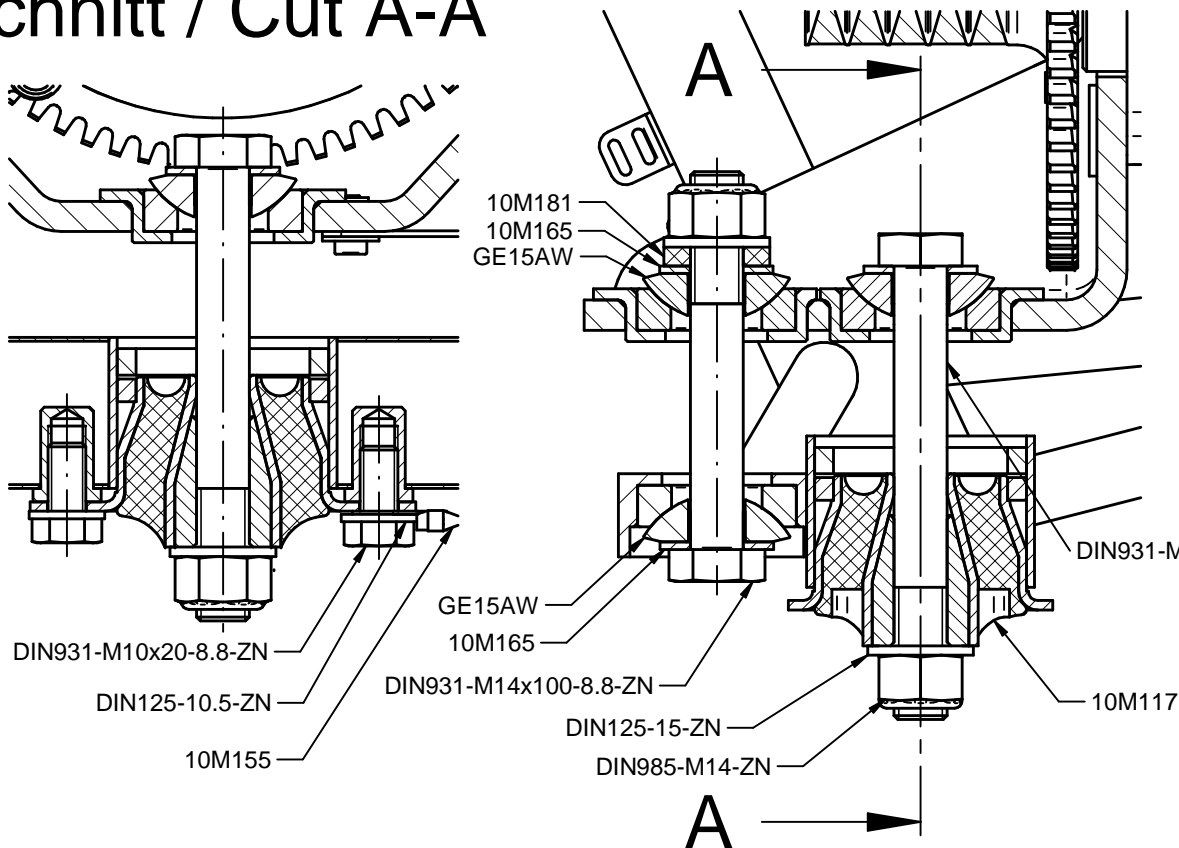

Motorlagerung vorne  
Engine mount front

Diagramm 20  
diagram 20

Ausgabe Sept. 2018  
issued Sept. 2018  
TM / TN 1000/40