

**Working instruction No. 2 for TN 1000/31
Mounting brackets for fuel injection system**

1. Remove the existing aluminium brackets.
2. Remove a small amount of material from the dummy sockets at both intake manifolds marked with X in the sketch below) to receive a clearance of approx. 1 mm between the intake manifolds and the new CFRP bracket 10M223/1.

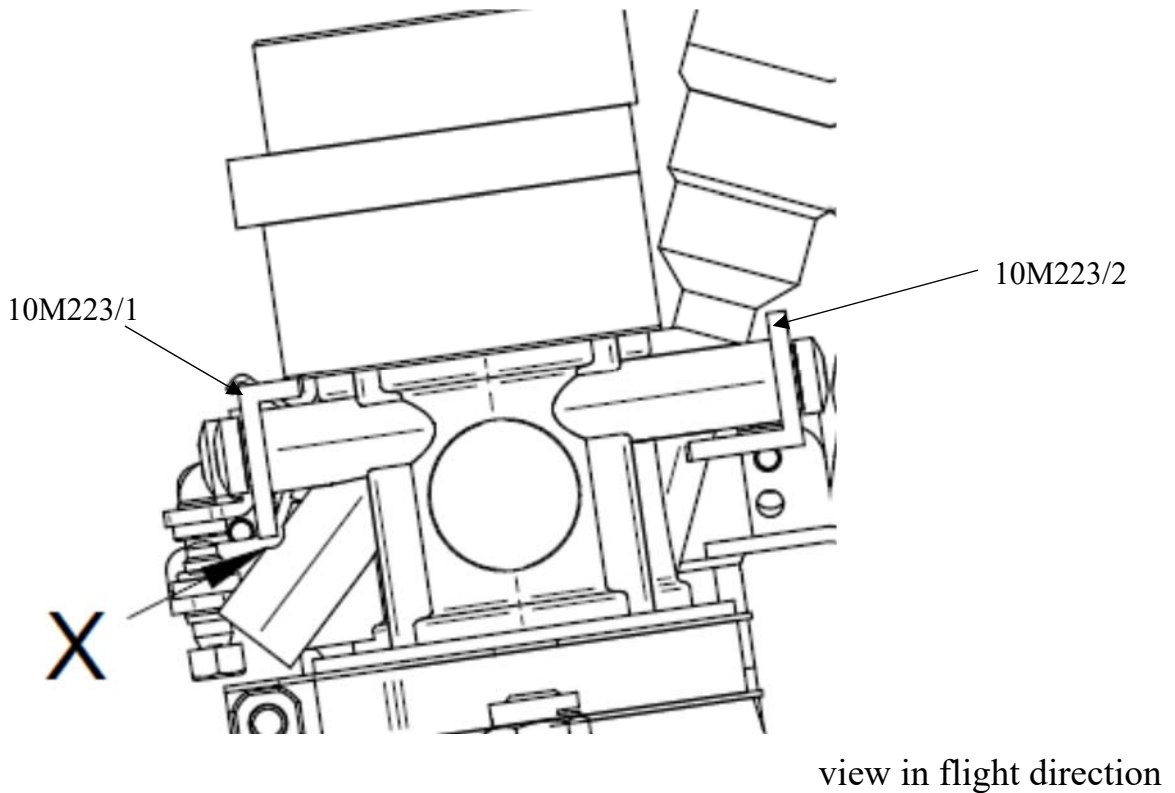

3. Install the new CFRP brackets, secure bolts with Loctite 243..
4. Material:

Part No.	amount	designation
41072231	1	mounting bracket outboard 10M223/1 (with steel stop-plate glued on)
41072232	1	mounting bracket inboard 10M223/2
30000305	1	Loctite 243