

**DG Flugzeugbau GmbH Inspection instruction No. 1 for TN1000/30
DG-1000M drive mount**

A. Checks according to TN1000/23. These checks must only be performed in case TN1000/23 instruction 2 (installation of stiffeners) has not been performed so far. Check during each daily inspection and during the 25 h inspection.

1. Extend the powerplant. Use a powerful torch to look at the left hand side to find the area shown in the picture below. Check for any cracks. Touch this area also with your fingers to find a crack.
2. It is nearly impossible to look and touch the right hand side with the engine extended, so retract the engine and stop before the engine doors close. Check the front (now upper side) of the left hand tube again and check also the right hand side. Touch around the tube with your fingers to find any crack on the lower side.
3. In case you find cracks don't operate the engine any more.

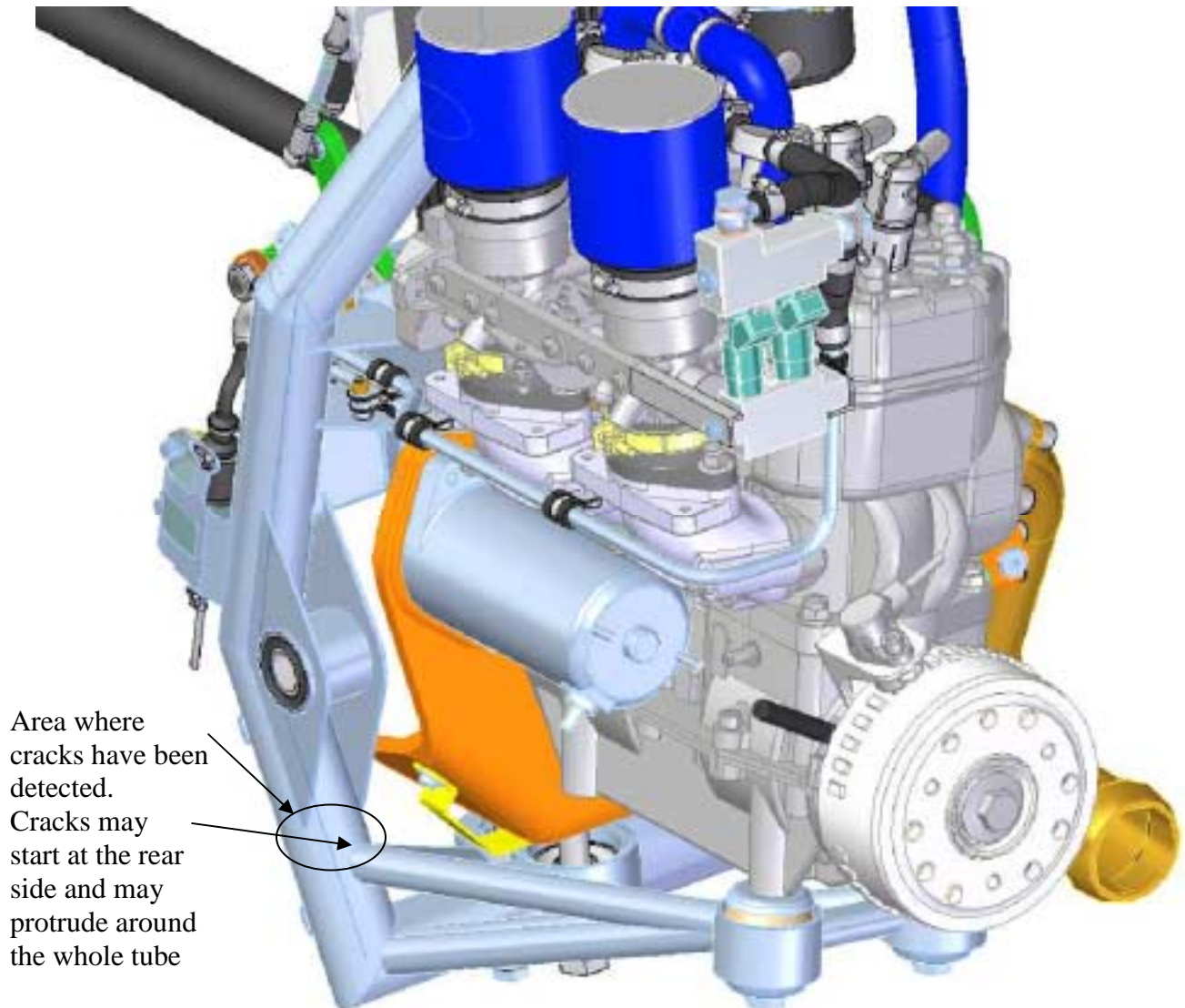

B. Checks for cracks at other areas of the drive mount. Check during each daily inspection and during the 25 h inspection.

1. Extend the power plant half-way, so that the front of the drive mount is completely visible.
2. Check the complete drive mount for cracks.
Especially check the right main tube in the area between the cross beams of the spindle drive and the cross tube of the lower radiator suspension for cracks, both the front as well as the rear parts. The area around the upper cross tube is partly covered by the drive belt cover. Checks of this areas see C.
3. Then check the left main tube between the two cross bars for cracks.
4. In case you find cracks don't operate the engine any more.

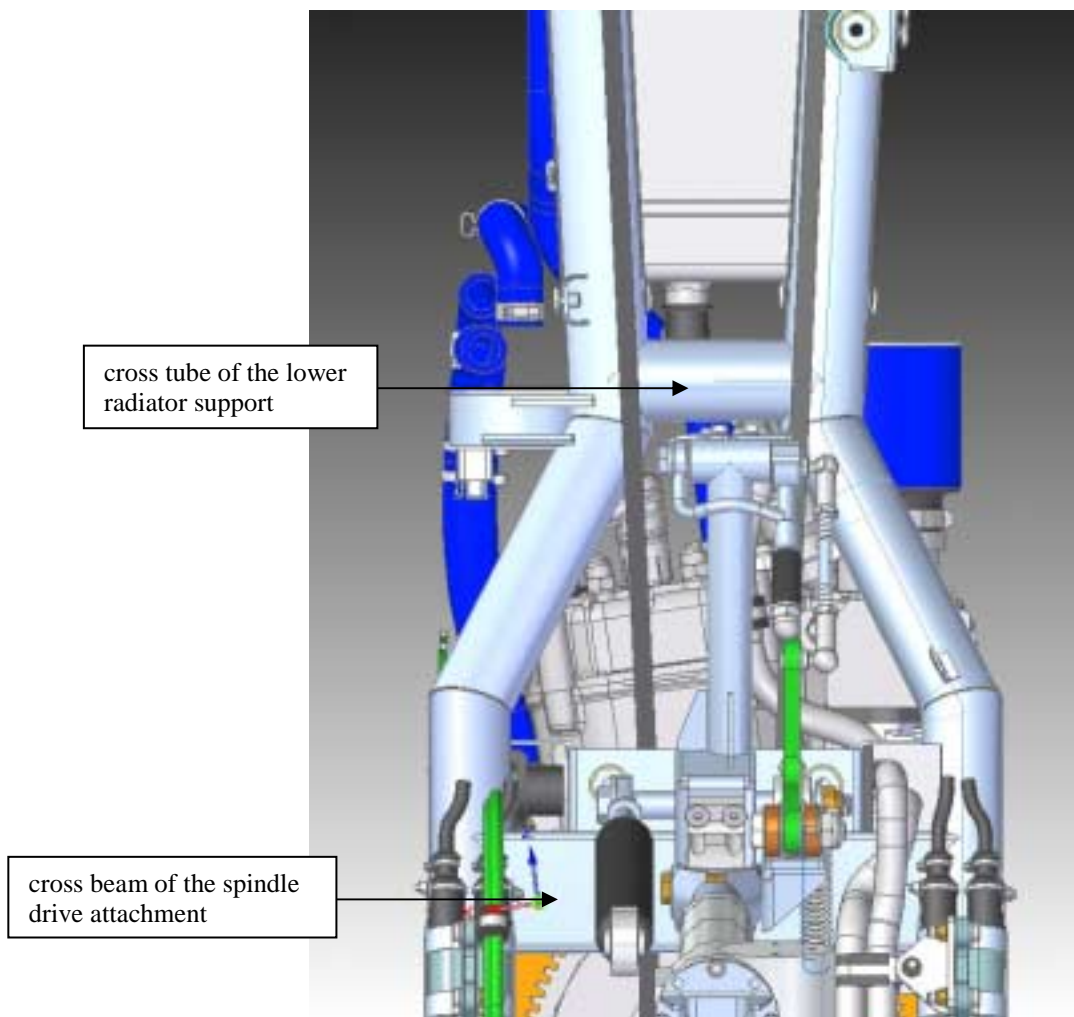

C. Checks for cracks in the areas of the drive mount covered by the drive belt fairings. Check every 5 engine hours and during the 25 h inspection.

1. In addition to the checks see B remove the drive belt fairings and check all areas visible now.
2. Re-install drive belt fairings. Secure screws with Loctite 243.

Caution: In case cracks are found according to TN1000/30 the drive mount must be exchanged against a mount of the new design prior to next engine use.