

Flight manual DG-1000S

Rev. No.	Affected Pages/section	Description	Issue Date	EASA Approval Date	Inserted Date Signature
8	0.5, 9.1-9.12	Electrically operated main landing gear	November 2008	28 January 2009	

Flight manual DG-1000S

0.2 List of effective pages (cont.)

Section	Page	issued	replaced/	replaced/
7	7.1	March 2002		
	7.2	"		
	7.3	"		
	7.4	"		
	7.5	"	Febr. 2008	
	7.6	"	June 2004	
	7.7	"		
	7.8	"		
	7.9	"		
	7.10	"	Sept. 2003	
	7.11	"	Oct. 2004	
	7.12	"		
	7.13	"	May 2008	
8	8.1	March 2002		
	8.2	"		
	8.3	"		
	8.4	"		
	8.5	"		
	8.6	"		
9	9.1	March 2002		
	9.2	"		
	9.3	"		
	9.4	"		
	9.5	"		
	9.6	"		
	9.7	"		
	9.8	"		
	9.9	"		
	9.10	"		
	9.11	"		
	9.12	"		

Flight manual DG-1000S

9 Supplements

Section		page
9.1	Introduction	9.2
9.2	List of inserted supplements	9.2
9.3	Electrically operated main landing gear	9.3 – 9.11

Flight manual DG-1000S

9.1 Introduction

This section contains the appropriate supplements necessary to safely and efficiently operate the sailplane when equipped with various optional systems and equipment not provided with the standard sailplane.

9.2 List of inserted supplements

Date of insertion	Document No.	Title of the inserted supplement
November 2008	Section 9.3	Electrically operated main landing gear TN1000/14

9.3 Electrically operated main landing gear

Introduction

In the following text the changes to those sections of the flight manual which are affected by the installation of the electrically operated main landing gear will be given

Section 1 General

1.4 Descriptive data

Subsection amended

With landing gear version A) the main landing gear may be operated electrically as an option, Version D).

D) Very high, spring mounted, electrically operated retractable main landing gear, wheel with hydraulic disc brake, tail wheel

With this version there are no handles and control rods for manual operation of the landing gear like Version A.

A landing gear warning device is integrated into the system.

Both cockpits are equipped with all controls and control lights

A manually operated emergency extension system is provided.

Technical data:

Extension and retraction time (electrically operated): approx. 7seconds

Extension time emergency operation: approx. 2 seconds

Flight manual DG-1000S

Section 2 Limitations

subsections amended

2.2 Airspeed

Note: VLO is not changed compared to the manually operated main landing gears

	Speed	IAS km/h (kts.)	Remarks
VLO	Maximum landing gear operating speed	185 (100)	Do not extend or retract the landing gear above this speed.
VLE	Never exceed speed in case the landing gear is not locked	150 (81)	Do not exceed this speed in case the landing gear is not locked, see emergency procedures sect. 3.20

Warning: If the landing gear is operated at speeds higher than VLO and if gusts generate accelerations higher than 4 g the landing gear may be damaged.

2.9 Approved manoeuvres

No aerobatic manoeuvres are allowed during extension and retraction of the landing gear and in case you fly with the landing gear is unlocked (see emergency procedures sect. 3.20).

2.10 Manoeuvring load factors

operating the landing gear	max. speed	g-load
	VLO	+4
		-2,65
in case the landing gear is not locked	VLE	+4
		-2,65

2.17 Limitation placards

Below the controls and control lights for the electrically operated landing gear see sect. 7.3:

LG ext.-retr. up to 185 km/h 100 kts.

Section 3 Emergency procedures

new subsection

3.19 Emergency extension of the electrically operated main landing gear

If extending the landing gear via the electrical system is not possible, the landing gear may be extended manually. The extension force is produced by a gas strut. For emergency extension pull on one of the 2 black-red emergency extension handles (located at the left hand fuselage wall, one in each cockpit), pull the handle until the landing gear is fully extended. The travel is about 15 mm (.6 in.), the extension time about 2 seconds. During extension the centre (red) LED is shining. When the landing gear is fully extended the lower green LED also starts shining.

Warning: Don't let the handle go before the green LED starts shining. If you don't pull for long enough the landing gear will rest in a position not locked over centre and will be destroyed at touch down.

Caution: If you execute the emergency extension at high airspeed it may take a longer time until the landing gear is fully extended. You should shorten the time by reducing the airspeed.

Caution: If emergency extension was necessary check the system to detect the failure and repair the system.

Resetting the system for normal operation see section 4.5.12.3.

3.20 Incompletely retracted electrically operated main landing gear

If the landing gear is not locked the centre (red LED) starts blinking approx. 22 seconds after the start of the retraction.

In this condition the retraction mechanism may be damaged with g-loads exceeding 4 g.

Instruction 1: Extend and retract the landing gear again.

Instruction 2: If instruction 1 was not successful extend the landing gear and land as soon as possible to fix the problem. For the remainder of the flight, don't fly faster than 150 km/h (81 kts.) and avoid abrupt manoeuvres.

Section 4 Normal procedures

4.2 Rigging and derigging

new subsection

4.2.8 Extension and retraction of the electrically operated main landing gear

Extension see 4.5.12.1 normal procedures

Warning: The main landing gear can only take up the weight of the glider when fully extended and locked. Therefore it is essential that during extension of the landing gear no load is applied to the main wheel. Lift the trailer ramp high enough. If there is a risk that the ramp may come down while the landing gear is extending secure the ramp, e.g. with blocks.

If such a case happens nevertheless switch the landing gear to retraction. To accomplish this you must switch up and hold the toggle switch and press the press button simultaneously 3 times within 2 seconds.

Warning: If you operate the retraction or extension the landing gear will travel to the up or down stop. So make sure that there are no obstacles which may be caught by the landing gear to prevent damage or injuries.

You can stop the travelling by switching the toggle switch in the reverse direction and pressing the press button simultaneously

4.5 Normal procedures

new subsection

4.5.12 Electrically operated main landing gear

4.5.12.1 Extension and retraction in flight

Retraction: For retraction switch and hold the toggle switch up and press the press button twice within 2 seconds. With each press on the button a signal will sound see section 4.5.16. The landing gear will retract automatically. You may let go of the switches. During retraction the centre (red) LED will shine and the upper green LED will blink. As soon as the landing gear is retracted and locked only the upper green LED will shine.

Warning: If the upper green LED doesn't start to shine and the red LED instead starts blinking refer to section 3.20 emergency procedures.

Extension: For extension switch the toggle switch down and let go.. The landing gear will be extended and locked.

During extension the centre (red) LED will shine and the lower green LED will blink. As soon as the landing gear is extended and locked only the lower green LED will shine.

Note: In case of high acceleration during extension or retraction an over current cut off system will switch off the spindle drive to protect the system. As soon as the g-loads decrease, the landing gear will continue to travel.

Note: To save electrical power during flight the upper green LED will stop shining after approx. 5 minutes, landing gear retracted and locked.

4.5.11.2 Extending the landing gear via the emergency extension system.

The emergency extension system is also designed to be operated for in flight training purposes. Operation see section 3.19.

Resetting the system for normal operation should be executed after landing, for procedure see section 4.5.12.3.

Caution: It is strongly recommended to train the emergency extension in flight.

Note: Resetting the system for normal operation is also possible in flight.

However, this is only permissible if there are 2 pilots on board, one pilot flying the glider and the other resetting the system.

Then you may retract the landing gear again according to section 4.5.12.1. to continue the flight.

4.5.12.3 Resetting the emergency extension system for normal operation

After an emergency extension the system must be reset for normal operation. To accomplish this you must pull one of the 2 emergency extension handles and simultaneously switch the toggle switch down. The centre (red) and the lower green LED will shine.

Switch and handle must be operated until the centre LED stops shining and only the lower green LED continues shining. The spindle drive will then stop operating, then let go handle and switch

Thereafter you may retract the landing gear again according to section 4.5.12.1.

4.5.12.4 Part extension and retraction for inspection and servicing

The retraction may be stopped by switching the toggle switch down,

The extension may be stopped by switching the toggle switch up and pressing simultaneously the press button.

Only the red LED will shine.

For any service work switch off the main switch!

With the procedures described in section 4.5.12.1 you may retract or extend the landing gear again.

4.5.12.5 Precautionary measures against retracting the landing gear while on the ground

If the glider is resting on the main landing gear the landing gear should not be retracted, as retraction will result in damage of the landing gear. To minimise the risk of such operating error the following safety features have been incorporated:

1. If the toggle switch is switched up, nothing will happen.
2. If the toggle switch is switched up and the press button is pressed 1 time a warning tone will sound, otherwise, nothing will happen.
3. Only if the toggle switch is switched up and the press button is pressed 2 times within 2 seconds the landing gear will be retracted.

Caution: If you leave the DG-1000 unattended switch off the main switch to prevent any operating error.

Section 7 Sailplane and system description

7.3 Cockpit, cockpit controls and placards

Subsection amended

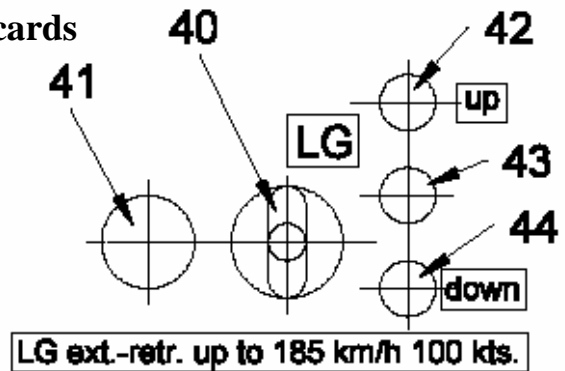

- 40) Toggle switch for extension and retraction of the electrically operated main landing gear
up retracted and locked
down extended and locked over centre
- 41) Press button for retraction of the electrically operated main landing gear
 For retraction switch and hold the toggle switch up and press the press button 2 times within 2 seconds.

42) – 44) control lights (LED's) for the electrically operated main landing gear:

Condition	control light indication
Normal operation	
LG retracted and locked	42) upper green shines
LG extended and locked	44) lower green shines
LG retracting	43) red shines, 42) upper green blinking
LG extending	43) red shines, 44) lower green blinking
LG stopped in intermediate position	43) red shines
Emergency operation	
LG extends	43) red shines
LG extended and locked	44) lower green shines, 43) red shines
System resetting	44) lower green shines, 43) red shines
Failure messages	
Time overflow: Signal appears if within 22 seconds after start of the travelling no limit switch activates	43) red blinking + upper or lower green blinking according to travel direction
One limit switch defective	all LED's blinking

Note: To save electrical power during flight the upper green LED will stop shining after approx. 5 minutes if the landing gear is retracted and locked.

Flight manual DG-1000S

45) Landing gear emergency extension handles – black-red
 The handles are located at the left hand fuselage wall, one in each cockpit at the positions of the handles for the manually operated landing gears, item 10).

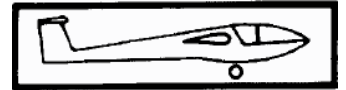

For emergency extension pull on one of the 2 red emergency extension handles, pull the handle until the landing gear is fully extended.

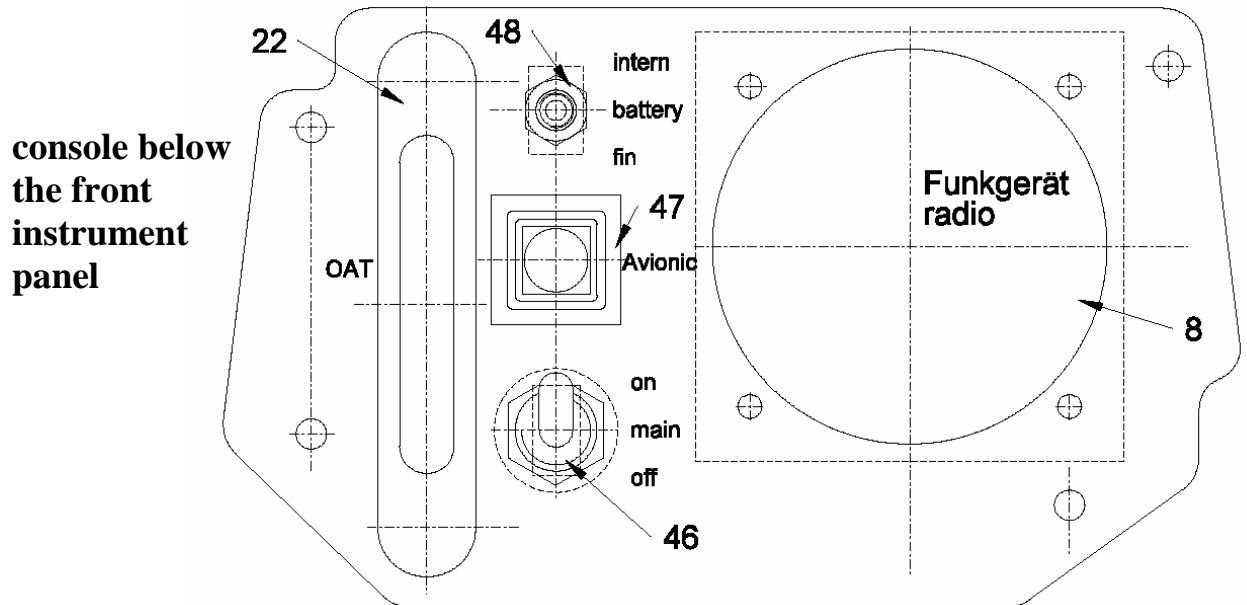

46) Main switch for the entire electrical system
 up= on

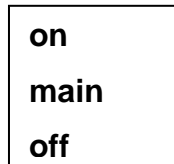

down= off

Note: If you don't operate the DG-1000, switch off the main switch. Otherwise the landing gear control unit will draw a small current and will empty the battery with time.

47) Circuit breaker for the instruments 4A



48) Selector switch for instrument power supply
 up= battery in baggage compartment

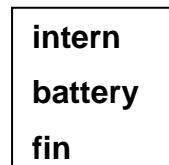

down= battery in the fin

Note: 26) Control light for the trim ballast box in the fin may not be installed at the position shown in the sketch on page 7.3 but at another suitable place in the front instrument panel.

7.6 Landing gear

Subsection amended

D) Very high, spring mounted, electrically operated retractable main landing gear, wheel with hydraulic disc brake, see diagrams 20 and 21 M.M, tail wheel
With this version there are no handles and control rods for manual operation of the landing gear like Version A.

In the normal operating mode the landing gear will be retracted and extended by an electrical spindle drive.

A control unit which is installed in the rear instrument tower controls all electrical functions and the control lights.

A landing gear warning device is integrated into the system.

Both cockpits are equipped with all controls and control lights

The landing gear will be locked in the extended position by over centre locking of the drag struts.

The landing gear will be locked in the retracted position by 2 latches.

The system is equipped with a safety circuit against retraction of the landing gear on the ground see section 4.5.12.5.

The system is equipped with an over current cut off which stops the extension or retraction if high accelerations occur to protect the drive against damage. As soon as the g-loads lower, the landing gear will continue to travel.

Emergency operation: If the electrical system is damaged or no battery power is available, the landing gear may be extended manually. The handles are located at the left hand fuselage wall, one in each cockpit at the positions of the handles for the manually operated landing gears).

Pulling on one of the 2 red emergency extension handles will open the valve of a lockable gas strut. The gas strut will push the spindle drive forward on a linear guide to extend and lock the landing gear.

Technical data:

Extension and retraction time (electrically operated): approx. 7seconds

Extension time emergency operation: approx. 2s

Power: 12V, max. 10 A

Flight manual DG-1000S

7.12 Electrical system

Subsection amended

Electrical system with electrically operated landing gear

Wiring see wiring plans 10E3 and 10E4 enclosed to the maintenance manual.

Batteries: To operate the electrically operated landing gear a battery Z01/2 must be installed in the baggage compartment. This battery must be equipped with a fuse G 250V 5x20 / 16A.

The battery in the fin Z110 (with fuse 4A) supplies power only to the instruments. The instruments may be switched by a selector switch in the front instrument panel to the battery in the baggage compartment.

Fuses and circuit breakers:

The electrically operated landing gear is protected by an automatically reset fuse in the landing gear control unit.

The wiring between battery and control unit is protected by the fuse at the battery.

The instruments are protected by a 4 A circuit breaker in the console below the front instrument panel.

Landing gear warning:

A landing gear warning device is integrated into the system. Warning is by a buzzer.