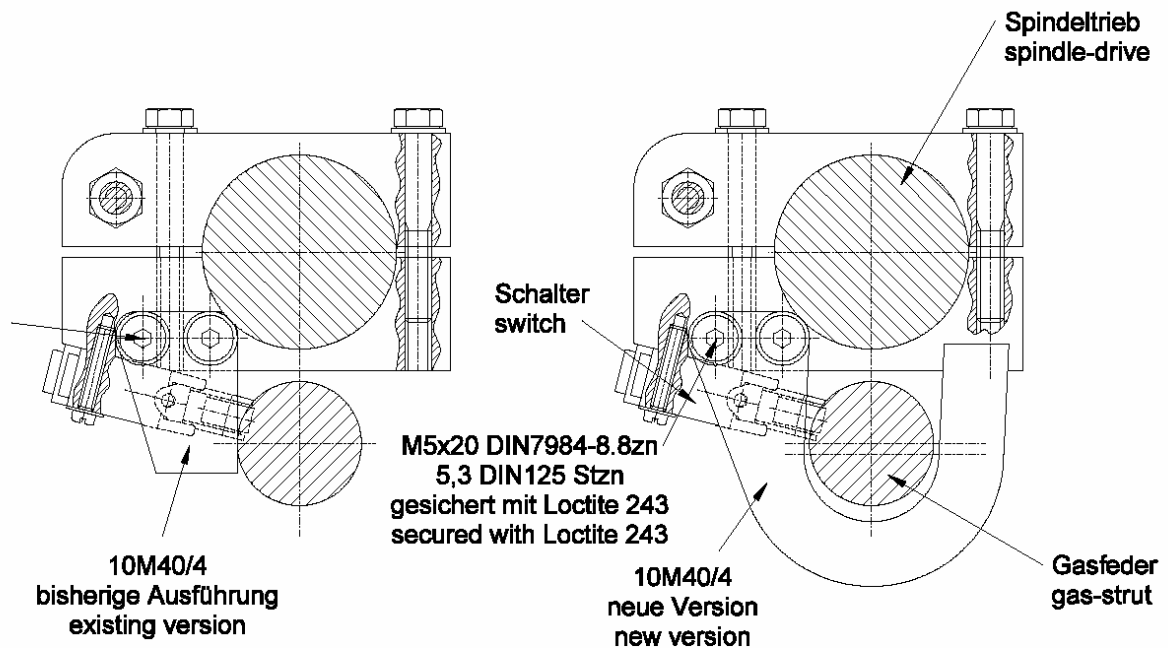

Working instruction No. 1 for TM1000/11

1. Extend the powerplant.
2. Remove existing part 10M40/4. Clean bolts and threads according to MM section 4.9.
3. Install new part 4M40/4. Secure bolts with Loctite 243 see MM section 4.9.
4. Extend the powerplant via the manual switch so far that the propeller-stopper doesn't quite start to move. The lever of the switch for the first stop (the lower one of the two switches mounted at the spindle drive) will be pressed towards its housing and switched "on".
5. Move the gas strut as far as part 10M40/4 allows in all directions. The switch shouldn't be switched "off" by moving the gas strut. You can hear if the switch is activated.
6. If the switch is switched „off“ while moving the gas strut, you have to remove the switch and bend it's lever so far that the end of the lever will remain approx 3 mm (1/8 in.) further away from the housing than before. Clean bolts and threads according to MM section 4.9. For reassembly secure bolts with Loctite 243 see MM section 4.9.
7. Check again according to item 5..