

vorderes Cockpit

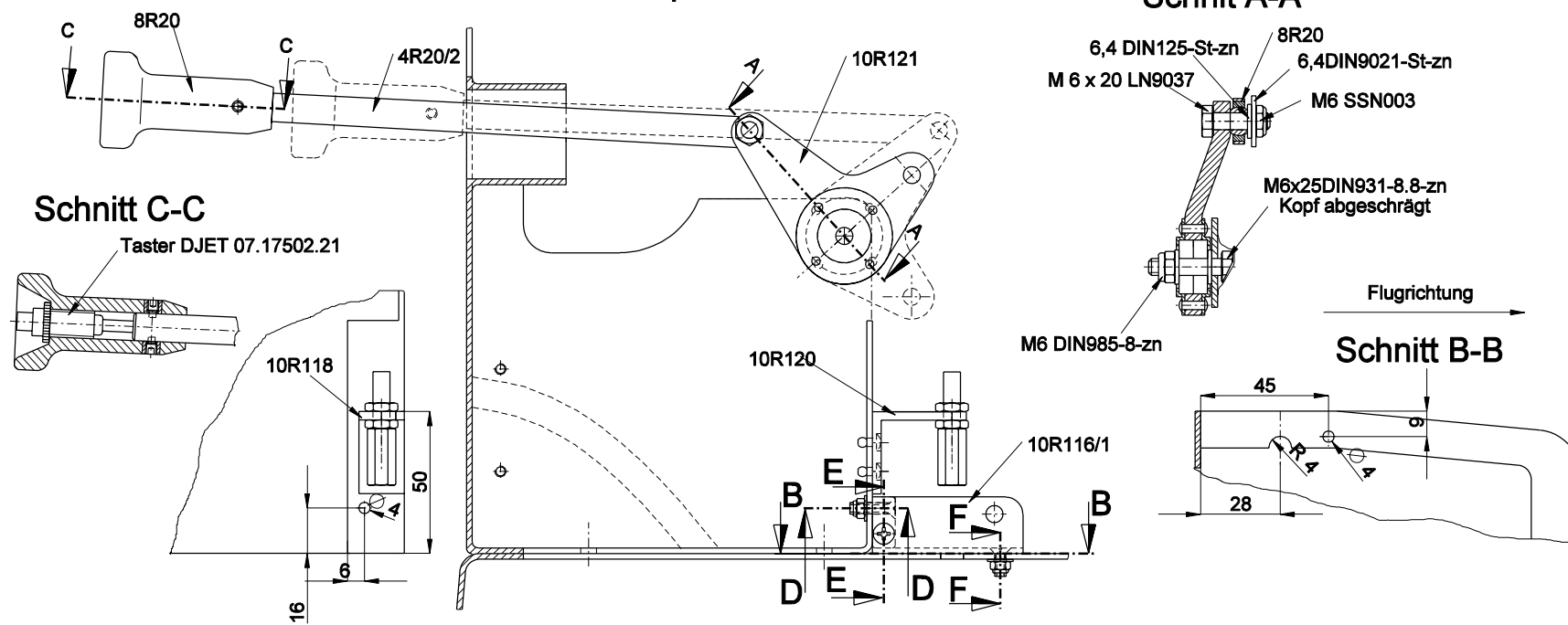

hinteres Cockpit

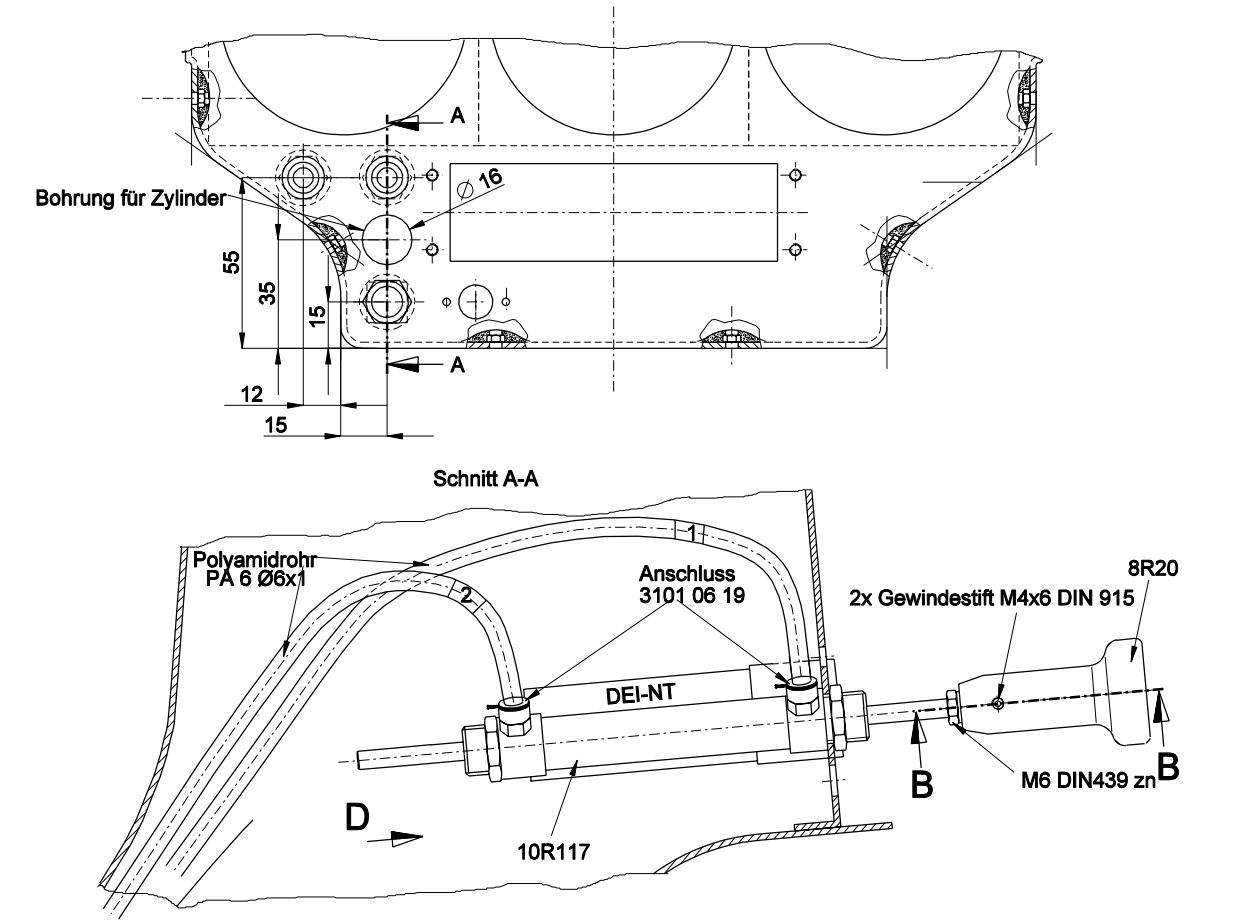

Schnitt D-D

Schnitt E-E

Schnitt F-F

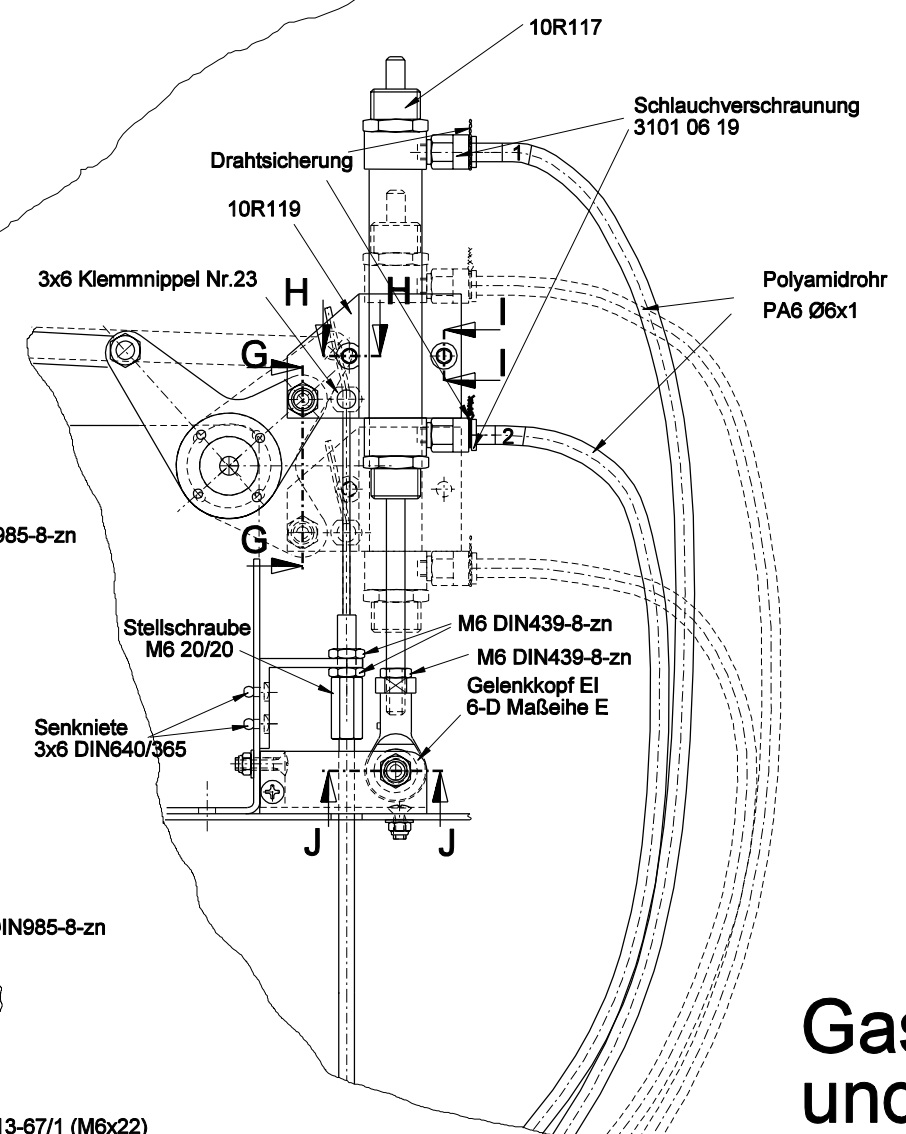
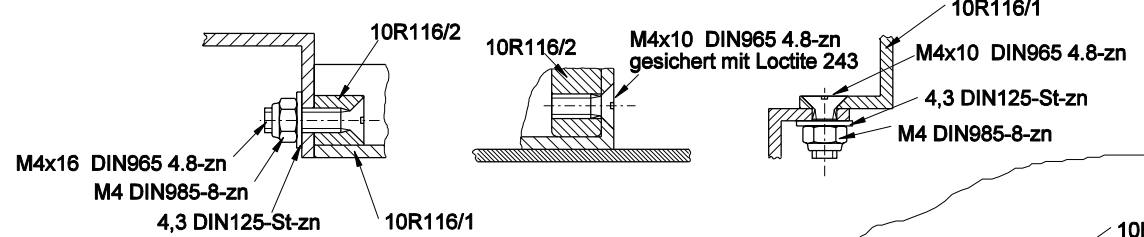

Schnitt G-G

Schnitt H-H

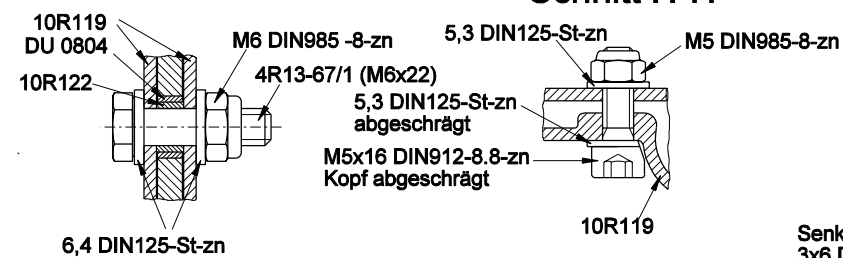

Schnitt I-I

Schnitt J-J

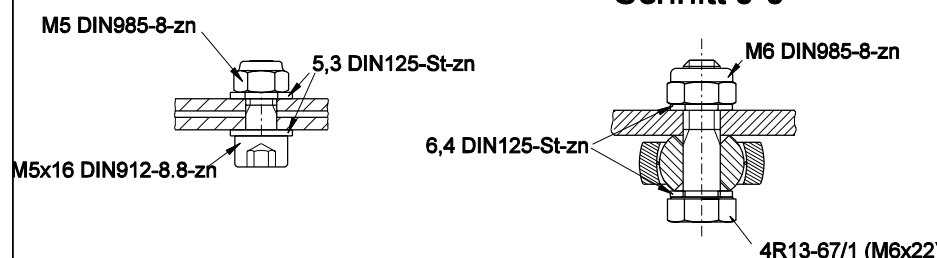

Schnitt B-B

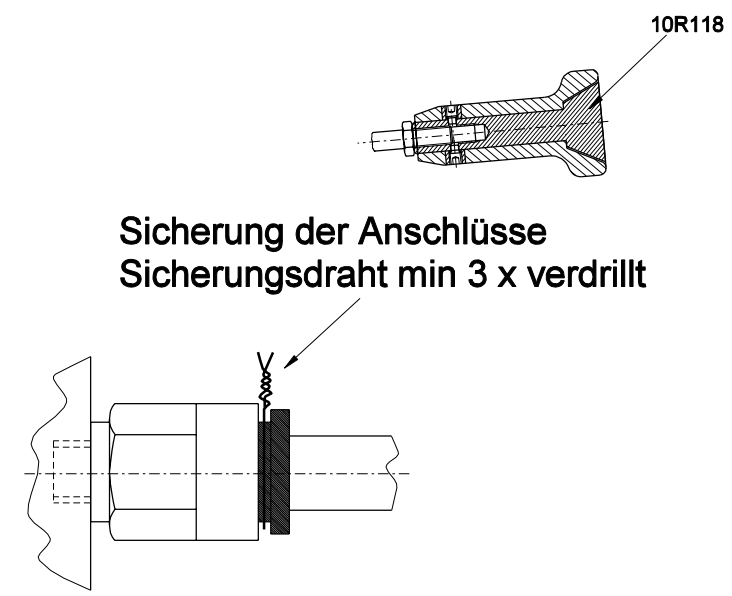

Diagramm 19

Gashebel im vorderen und hinteren Cockpit

Ausgabe März 2008  
 TM1000/15